



SÖRG
Rollstuhltechnik

Tilty Vario

User Manual



IMPRINT

SORG Rollstuhltechnik GmbH+Co.KG
Benzstraße 3-5
D-68794 Oberhausen-Rheinhausen
Germany

Tel. +49 7254-9279-0
Fax +49 7254-9279-10
E-mail info@sorgrollstuhltechnik.de
Web www.sorgrollstuhltechnik.de

REVISION STATUS

Revision from April 25, 2016

TECHNICAL STATUS

Technical changes and misprints reserved. The pictures in this user manual can – depending on the individual equipment – differ from the actual equipment components. However, a corresponding conduction is possible.



REHAKIND



We are a member of rehaKIND e.V.
International association
child and adolescent rehabilitation

COPYRIGHT

© by SORG Rollstuhltechnik GmbH + Co. KG Benzstraße 3-5, 68794 Oberhausen-Rheinhausen.
All texts and pictures in this user manual underlie the international copyright protection and are not allowed to be published without our consent – not even in excerpts!

CERTIFICATION

We are certified according to the Quality Management System ISO 90001:2008 under the certificate no. 12 100 20070 at TÜV SÜD.



IMPRINT	2	A GAS PRESSURE SPRING	19
REVISION STATUS	2	3.3.6 FOLDING THE BACK ANGLE DOWN WITH A GAS PRESSURE SPRING	19
TECHNICAL STATUS	2	3.4 PUSH AIDS	20
REHAKIND	2	3.4.1 PUSH HANDLES/PUSH BAIL	21
COPYRIGHT	2	3.4.2 CLAMPING FORCE OF THE ECCENTRIC CLAMP	22
CERTIFICATION	2	3.4.3 ANGLE ADJUSTMENT PUSH BAIL	22
WHEELCHAIR OVERVIEW	4	3.4.4 PUSH AID FOR OUTSIDE (OUTDOOR FRONT END)	23
1 Preamble	5	3.5 LEG SUPPORTS	24
1.1 GENERAL INFORMATION	5	3.5.1 LOCKING AND UNLOCKING THE FOOT PLATE/S	24
1.2. SIGNS AND SYMBOLS	5	3.5.2 STANDARD LEG SUPPORT, CONTINUOUS OR DIVIDED	25
1.3 INDICATION	5	3.5.3 LEG SUPPORT CAN BE ELEVATED, CONTINUOUS OR DIVIDED	26
1.4 COUNTER INDICATION	5	3.5.4 LEG REST	26
1.6 APPLICATION	6	3.6 BRAKES	27
1.7 RECEPTION	6	3.6.1 STANDARD WHEEL LOCK	27
1.8 DOCUMENTATION	6	3.6.2 CABLE BRAKE	27
1.5 SPECIFICATION TILTY VARIO	6	3.6.3 DRUM BRAKE AS DRIVING BRAKE	28
1.9 SERVICE AND MAINTENANCE	7	3.6.4 DRUM BRAKE AS WHEEL LOCK	28
1.10 ACCESSORY AND ATTECHMENT DRIVES	7	3.7 ANTI-TIPPER	29
2 Safety Instructions	7	3.8 THORAX TRUSS PADS	30
2.1 GENERAL INDICATIONS	7	3.9 ABDUCTION WEDGE	30
2.2 HANDLING	8	3.10 HEAD RESTS	31
2.2.1 GETTING IN AND OUT	8	3.11 THERAPY TABLE	31
2.2.2 STARTING AND SLOWING DOWN	9	3.20 ARM CUSHION	32
2.2.3 DANGER OF TIPPING AND FLIPPING OVER	9	3.20 TIPPING LEVER	32
2.2.4 UP AND DOWNHILL	10	3.21 CANE HOLDER	33
2.3 GRABBING OBJECTS	10	3.4 ONE-HAND STEERING	33
2.4 OVERCOMING OBSTACLES	11	4. Repairs and maintenance	34
2.5 WHEEL LOCK	11	4.1 REPAIRS	34
2.6 ANTI-TIPPER	12	4.2 SPARE PARTS	34
2.7 CASTERS	12	4.3 DISPOSAL	34
2.8 LOADING AND TRANSPORTING	12	4.4 TIRE CHANGE	34
2.8.1 TRANSPORT IN PUBLIC TRANSPORTATION	13	4.5 MAINTENANCE	35
2.8.2 TRANSPORT IN OTHER VEHICLES	13	4.5.1 CLEANING AND CARE	35
2.9 OTHER RISKS	13	4.5.2 DISINFECTION	35
3 Handling	15	4.5.3 REINSTATEMENT	35
3.1 ASSEMBLY GROUP WHEELS	15	4.6 SERVICE/INSPECTION	36
3.1.1 QUICK RELEASE AXLE WHEELS	15	4.6.1 CHECK LIST	36
3.1.2 DRUM BRAKE WHEELS	15	4.6.2 CHECK LIST YEARLY INSPECTION	36
3.1.3 CASTERS	16	4.6.3 SERVICE LIST	36
3.2 SPECIAL HAND RIMS	16	4.7 TECHNICAL DATA	38
3.2.1 DOUBLE HAND RIM	16	4.7.1 MEASUREMENTS AND DIMENSIONS	38
3.2.2 KNOB HAND RIMS	17	4.7.2 MEANING OF LABELS	38
3.2.3 HAND RIM COVERS / MAXGREPP HAND RIMS	17	4.7.3 MEASUREMENTS TILTY VARIO	38
3.3 SEAT-BACK UNIT	17	4.8 DOCUMENTATION YEARLY INSPECTION	39
3.3.1 TILTING	17	4.9 RETAILER VERIFICATION	40
3.3.2 ADJUSTING THE BACK ANGLE	18		
3.3.3 FOLDING THE BACK DOWN	18		
3.3.4 SUBMERSIBLE BACK EXTENSION	18		
3.3.5 ADJUSTING THE BACK ANGLE WITH			

Wheelchair overview

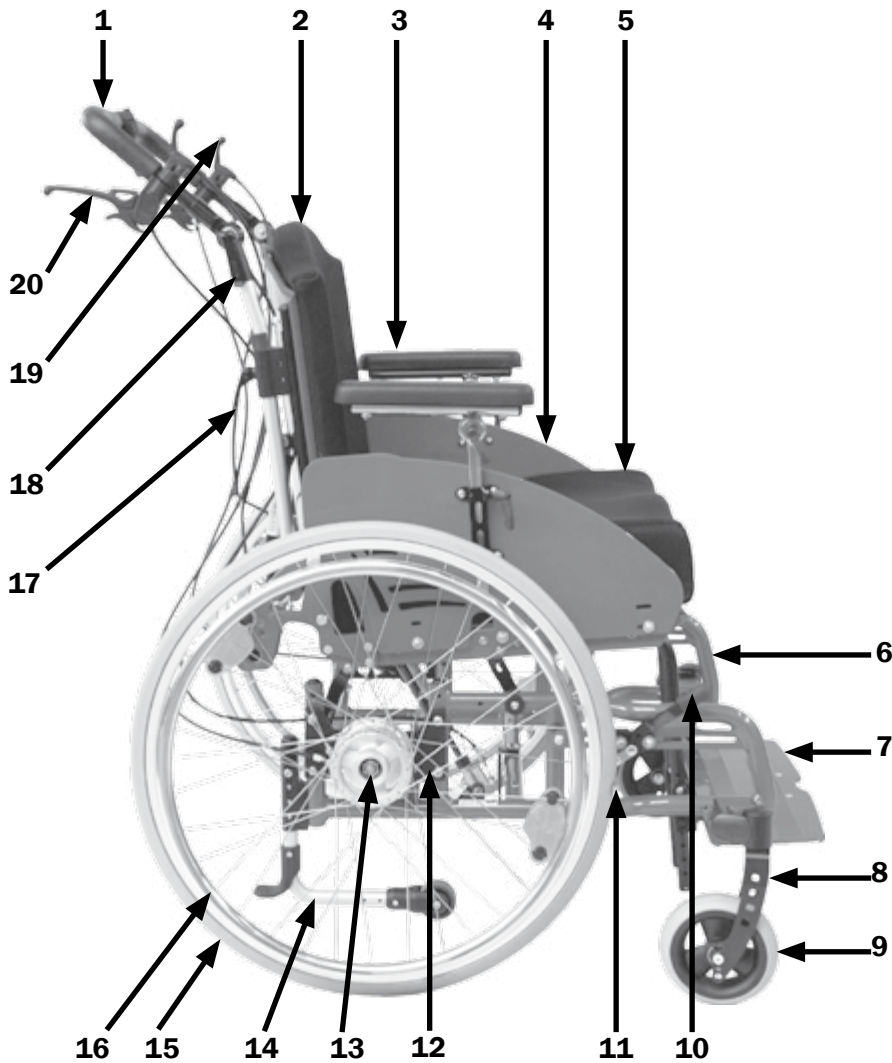

1. push bail, angle adjustable
2. firm curved back plate, angle adjustable
3. arm rest, height and angle adjustable
4. side guard
5. anatomically formed seat
6. frame
7. foot plate, folds back
8. caster fork
9. caster
10. control lever for knee lever brake
11. brake pressing bolt
12. axle plate
13. drum brake hub with quick release axle
14. anti-tipper
15. driving wheel
16. handrim
17. clamp lever height adjustment push bail
18. clamp lever angle adjustment push bail
19. release lever gas pressure spring for back angle adjustment
20. control lever drum brake

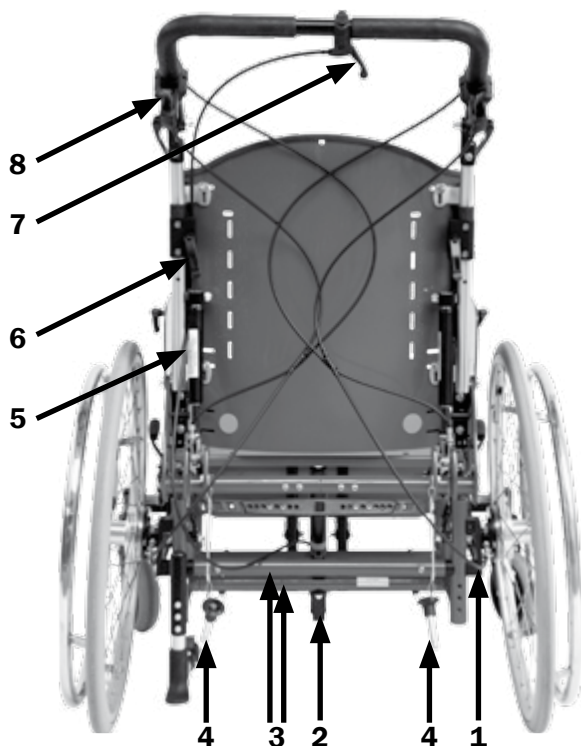

1. axle plate with camber adapter
2. gas pressure spring for tilting
3. frame crossbar (screwed on for growing feature)
4. plug bolt to lock the back gas pressure spring
5. gas pressure spring for back angle adjustment
6. eccentric clamp for the height adjustment of the push bail
7. release lever seat tilt mechanism
8. control lever drum brake

1 Preamble

1.1 GENERAL INFORMATION

The wheelchair has been built, adjusted and given to you operable according to your individual instructions. A qualified Technician will make any changes necessary, should modification be needed during use.

As any other aid, a wheelchair is a technical device that can hold risks if not properly used. This brochure is to help you familiarize yourself with the wheelchair and its functions.

ATTENTION

Read the following instructions and manuals carefully.

 User manual

 Info-brochure Crash Test ISO 7176-19

ATTENTION

If the user of the wheelchair is a child or a person with limited competence, the parents or authorized supervisor have to make sure that they have fully understood the handling of the wheelchair before it is first used.

If you have any questions your medical supply store or our competent team is glad to assist you (+49 07254/92790).

1.2. SIGNS AND SYMBOLS

ATTENTION

This is how **individual-related** safety aspects of **utmost importance** are indicated.

▶▶ INDICATION

This is how possible **indications** of **utmost importance** are labelled.

INFORMATION

This is how **INFORMATION** on mounting and adjustment work is labelled.

READ

This refers to other chapters within the brochure or to additional material.

BOLD PRINT

Text in bold print highlights important passages or remarks.

1.3 INDICATION

Tilty Vario is indicated

- by all therapy forms for changing positions
- to stimulate/strengthen the whole metabolism, the nervous system and or the whole cardiovascular system,
- to preserve, rebuild and to activate the whole muscle tone or individual muscle groups,
- to build and to strengthen the whole bone structure,
- to slow or to limit the development of scoliosis,
- to slow or to limit atrophic or dystrophic muscle changes,
- to stimulate/strengthen the sensitive integration (perception or vestibular stimulation),
- by all forms of Paresis and/or neuromuscular sicknesses,
- to reactivate after a severe concussion,
- by all therapy forms in reference to side dominance.

1.4 COUNTER INDICATION

Tilty Vario is as an active wheelchair counter indicated by:

- grave vestibular and perception disorder,
- limb loss on both arms,
- joint contractures/joint damages on both arms,
- unable to sit,
- not enough eyesight.

ATTENTION

Under the following circumstances and/or symptoms, the active and/or passive use of the Tilty Vario must be thoroughly discussed with the doctor or therapist in charge of treatment:

- **users without intact skin,**
- **with severe tonicity deregulation**
- **or with severe motor disfunctions.**

▶▶ INDICATION

We are NOT liable for health problems and/or other damages on persons or objects that occurred from using the Tilty Vario despite the above described conditions.

1.5 SPECIFICATION TILTY VARIO

Tilty Vario is a growable active wheelchair with tilt function for children, adolescents and adults:

- **Seat height and seat position** can be set,
- **tilt function** with gas pressure spring by 25°,
- **back angle adjustment** with raster from 78° to 126°, in addition can be folded forward
- frame **abducted** by 10 cm,
- **back height** growable by 5 cm, **seat width** growable by 4 cm and **seat depth** growable by 4 cm without purchased parts
- various **side guards** (with built in cable control among other things),
- **anti-tipper,**
- **leg supports** with continuous or divided foot plates, mounted in the middle under the seat, distance can be set freely, opt. can be elevated,
- **steer and push aids** for outdoors (Outdoor Front End),
- **positioning aids** (side truss pads, abduction wedge, anatomically formed seat unit, head rest, telescopic back extension),
- **one-hand aid** (double hand rim, one-hand steering, one-hand brake),
- legrest(s),
- suitable for setting up a seat shell,
- **various driving wheels and casters.**

1.6 APPLICATION

ATTENTION

The wheelchair serves solely to actively or passively transport the person whom the wheelchair has been adjusted for by a qualified specialized trade.

It can be used on firm ground without any restrictions indoors and outdoors. With suitable equipment (e.g. Outdoor Front End) the wheelchair can also be used on surfaces such as sand, cobblestones, gravel etc.

ATTENTION

The allowed load capacity (including seat shell if applicable) is not to be exceeded.

ATTENTION

The wheelchair cannot be used in extremely wet surroundings (shower, sauna, etc.) or salt water nor can it have excessive contact with moisture.

ATTENTION

The wheelchair must not be used as means of transportation for goods, objects and the like.

INFORMATION

Please follow the care and maintenance plan.

1.7 RECEPTION

▶▶ INDICATION DELIVERY

Each wheelchair is mounted, tested for functionality and correctness in our works and packaged into special cardboard boxes by our shipping experts.

FORWARDING COMPANY

For liability reasons we have to ask you to check the wheelchair immediately after receiving it and in the presence of the deliverer (forwarding company) for possible damages that may have occurred during transportation.

TRANSPORTATION DAMAGES

In case of damage, please proceed as follows:

- write a short record of the damage and review of events, if possible include pictures clearly showing the damage,
- get the personal information of the bearer (driver's license etc.),
- inform us immediately.

▶▶ INDICATION

Do not sign the notice of receipt from the forwarding company before thoroughly checking the wheelchair for defects.

▶▶ INDICATION

According to the valid law, damages reported late can neither be asserted to us nor to the forwarding company!

1.8 DOCUMENTATION

▶▶ INDICATION

Keep this user manual in a safe place. Have all work/repairs done on your wheelchair documented by the medical supply store in the maintenance plan. If applicable, hand it back to your benefactor along with the wheelchair.

▶▶ INDICATION

In the event of the wheelchair being reused, this is an important source of information for your benefactor. It provides evidence of regular inspections which might be relevant in the event of warranty claim.

ATTENTION

For safety reasons have all repairs done and documented solely by a qualified specialized trade.

1.9 SERVICE AND MAINTENANCE

READ

According to § 33 subparagraph 1, clause 4, [German] SGB V, the responsibility of maintenance, repairs and replacement lies with the benefactor. After agreement with your benefactor, be sure to have all safety relevant inspections, maintenance work and if necessary repairs conducted in order to make the wheelchair functional.

ATTENTION

Be careful with all moveable parts since there is a **RISK** of crushing fingers and other body parts.

ATTENTION

The regular inspection of all safety relevant parts on the wheelchair by a qualified rehab workshop is the only way to prevent damages and maintain our liability.

ATTENTION

Only original parts are to be used for all service and maintenance work.

INFORMATION

Proceed according to the maintenance plan in chapter 4 of this user manual.

1.10 ACCESSORY AND ATTACHMENT DRIVES

ATTENTION

The addition of these accessory and attachment drives is done by either the manufacturer or the sanitary house and solely in their responsibility.

INFORMATION

Ask the manufacturer for the respective requirements.

2 Safety Instructions

2.1 GENERAL INDICATIONS

ATTENTION

The risk of injuries is on all rotatable and turnable parts. This also goes for adjustment and repair work.

READ

Before use read this user manual thoroughly.

ATTENTION

The wheelchair can only be used according to its specifications. Any other use or misuse can contain serious risks for you and your surroundings. Also the guarantee or product liability can be terminated in case of misuse!

Slowly familiarize yourself with the wheelchair at the first use and after adjustment work has been done. First practice on level grounds with the help of an experienced person. Only then are you allowed to try uphill and downhill with the help of an experienced person.

From putting on and taking off the accessories, the measurements of the wheelchair, its weight, the handling and tilting changes.

Under certain circumstances the wheelchair can tip over backwards on level grounds with a back tilt of $>90^\circ$. This also occurs also and to a special degree when the seat position is tilted.

ATTENTION

THE WHEELCHAIR CAN ONLY BE USED WITH ACTIVATED ANTI-TIPPER WHEN TILTED AND/OR A BACK ANGLE OF $>90^\circ$.

ATTENTION

All mounting alterations must be coordinated and documented.

ATTENTION

Do not make any adjustments, repairs and/or do maintenance work yourself. Contact your qualified medical supply store.

READ

Consider the indications for maintenance and inspection on your wheelchair at the end of the operating instructions.

2.2 HANDLING

2.2.1 Getting in and out

⚠ ATTENTION

(1+2) Getting in and out can only occur on a flat surface and with **ACTIVATED WHEEL LOCK**. The seat cannot be tilted. Activate the anti-tipper for each transfer and turn the casters forward.

⚠ ATTENTION

(1) **NEVER** use the footrest/s in order to get in or out. Fold them back.

▶▶ INDICATION

(3) For some children it is asked for, therapeutically, that they get in and out on their own by using the footrest. In this case consider the following:

- turn the casters forward,
- secure the wheelchair from rolling away,
- activate the anti-tipper and assist.

(4) Active transfer:

- Drive as close as possible to the front of the chair or seat.
- Secure the wheelchair from rolling away and activate the anti-tipper.
- Support yourself with one hand on the new seating area (the chair) and with the other one on the wheelchair.
- Turn your pelvis by shifting your weight in the direction of the new seating arrangement.
- Changing back proceed analog.

(5) Transfer with sliding board

- Drive as close as possible to the side of the chair.
- Secure the wheelchair from rolling away and activate the anti-tipper.
- Place the one end of the sliding board under your thigh and the other on the chair.
- Pull yourself on the sliding board to the chair.
- Changing back proceed analog.



2.2.2 Starting and slowing down

⚠ ATTENTION

Avoid jerky starts. The wheelchair could tip backwards. With children we recommend, whenever possible, to use a headrest.

⚠ ATTENTION

When driving downhill more strength is required. This is why you should drive slow enough downhill that you are able to bring the wheelchair to a full stop at any time.

⚠ ATTENTION

Hand rims heat up from friction. If necessary, use gloves with a leather inner surface as used by cycling but NEVER wool gloves.

2.2.3 Danger of tipping and flipping over

Special caution is necessary when driving (active and passive) with a tilted seat and/or a back angle greater than 90°, because the centre of gravity is massively changed by this and it can become wobbly on a level surface.

⚠ ATTENTION

WE RECOMMEND, IF POSSIBLE, NOT TO DRIVE OR OVERCOME OBSTACLES WITH A TILTED SEAT AND/OR BACK ANGLE >90°. FOR THIS ALWAYS PLACE THE SEAT AND THE BACK IN A VERTICAL POSITION!

⚠ ATTENTION

DO NOT HANG OBJECTS (BAGS ETC.) ON THE BACK OR THE BACK TUBES/ PUSH HANDLES/ BAIL. WITH THIS YOU INFLUENCE THE TILT BEHAVIOUR OF THE WHEELCHAIR MASSIVELY.

⚠ ATTENTION

Generally the hazard of flipping and tipping over occurs

- (1) from all kinds of height differences of the ground surface,
- (2) from chairs (never manage alone),
- (3) from participation in public traffic under the influence of medication, drugs, alcohol etc.,
- (4) when leaning out of the wheelchair,
- (5) from longitudinal grooves (streetcar rails etc.), curbsides etc. Always cross at 90° angle,
- (6) from driving uphill and/or objects which change the centre of gravity on the back, driving with tilted seat. If possible, lean your upperbody as far as possible in the direction of the hill.

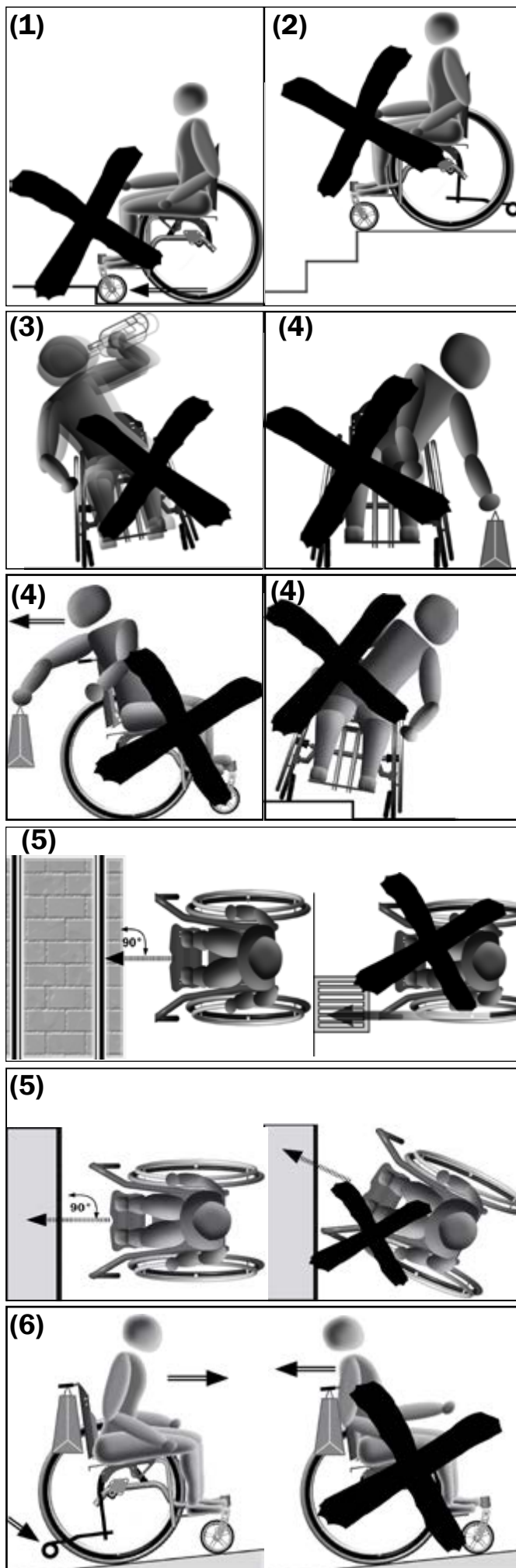

2.2.4 Up and downhill

⚠ ATTENTION

Keep in mind the higher strain in order to drive/push or brake going up or downhill.

⚠ ATTENTION

Be sure to check the **FUNCTIONAL EFFICIENCY OF THE WHEEL LOCK** and the drum brake **BEFORE EACH DRIVE**.

⚠ ATTENTION

The seat and back unit must be in a vertical 90° position when driving on inclines/descents.

⚠ ATTENTION

(1) If possible, the user should tilt their body when driving up or downhill in the direction of the hill.

⚠ ATTENTION

Only go up/down ramps or hills with an incline or descent greater than 6% with assistance.

⚠ ATTENTION

NEVER go on ramps or hills **WITHOUT** the anti-tipper activated.

⚠ ATTENTION

(2) **NEVER** drive on inclines, descents or curbs sideways to the road, you may tip over.

2.3 GRABBING OBJECTS

Grabbing objects requires some practice and experience. Slowly familiarise yourself with the action with the help of an experienced and strong assisting person.

(3) In order to grab objects from the side/in front of the wheelchair

- secure the wheelchair from rolling away,
- do not lean too far out the wheelchair,
- hold on with your free hand (if possible),
- try to shift as little weight as possible in the grabbing direction.

(4) If you have to lean forward out of the wheelchair, **NEVER STRAIN THE LEG SUPPORTS, DANGER OF FLIPPING OVER!**

- For a better stance, turn the casters forward by driving back a little bit,
- (if possible) place both feet on the ground and as far forward as possible,
- (if possible) secure yourself with your free hand as far back as possible,
- try to shift as little weight as possible in the grabbing direction.

▶▶ INDICATION

Generally, using a reacher is safer.

⚠ ATTENTION DANGER OF FLIPPING OVER!

Do not grab objects behind the wheelchair over the wheelchair back. Turn your wheelchair and drive toward the object from the front or side.

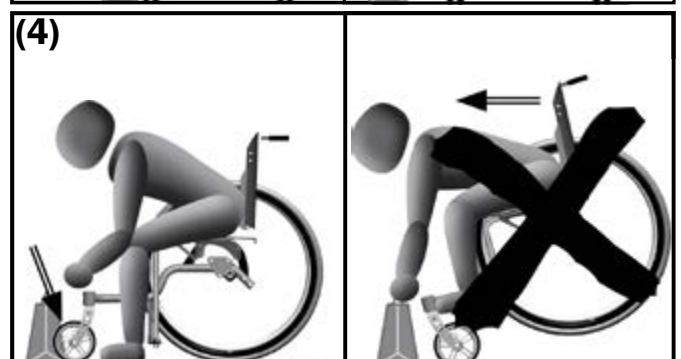
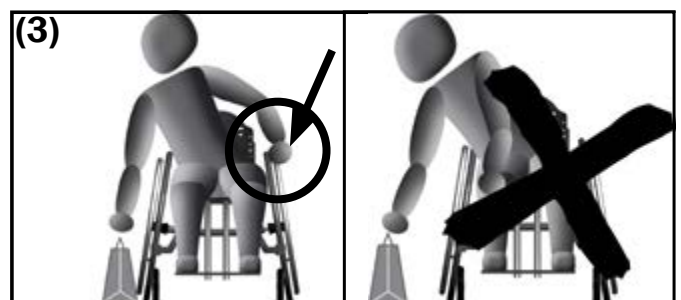
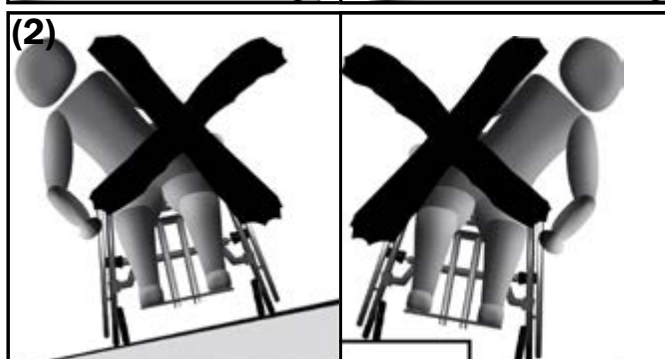
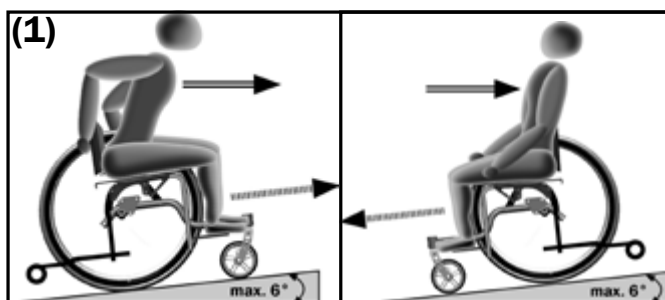

2.4 OVERCOMING OBSTACLES

A WHEELCHAIR IS NOT FOR CARRYING. For this reason avoid stairs! Whenever possible, use ramps or elevators in order to overcome height differences.

⚠ ATTENTION

BE SURE THAT THE ECCENCTRIC CLAMPS OF THE PUSH HANDLES/BAILS ARE TIGHTLY LOCKED AND EFFECTIVE.

⚠ ATTENTION

ONLY CARRY THE WHEELCHAIR BY ITS FRAME, NEVER BY THE SEAT SHELL, THE LEG SUPPORT AND/OR THE FOOT PLATE/S.

⚠ ATTENTION

(1) NEVER overcome stairs etc. with the wheelchair ALONE.

⚠ ATTENTION

(2+3) Only overcome stairs with the help of two experienced people. For this, the anti-tipper must be deactivated. Be sure that the wheelchair is only held by metal parts which are screwed securely to the frame.

⚠ ATTENTION

Do not under any circumstances use escalators, not even with a carer! Shopping malls and public buildings with escalators always have elevators as well.

⚠ ATTENTION DANGER OF FLIPPING OVER

Do not drive towards, for example, curbsides without braking!

⚠ ATTENTION

(4) In order to overcome height differences or when using an elevator and lifting platforms, you generally have to deactivate the anti-tipper. You could become restricted in maneuverability.

(5) In order to overcome curbsides your carer should slightly tilt you backwards, lift both casters over the threshold and then, with the driving wheels, carefully push the wheelchair over the edge. The anti-tipper must be deactivated.

When driving off of the curb the casters must stay in the air until the driving wheels have driven over the threshold.

⚠ ATTENTION DANGER OF FLIPPING OVER

DO NOT put the casters down first. The wheelchair could flip forward with the occupant.

2.5 WHEEL LOCK

⚠ ATTENTION

THE KNEE LEVER BRAKES ARE ONLY TO PLACE THE WHEELS IN A RESTING POSITION. THEY ARE NOT DESIGNED TO BRAKE THE WHEELCHAIR FROM DRIVING.

A service brake, such as a drum brake, allows controlled braking.

⚠ ATTENTION

Before each (longer) drive be sure to check

- the correct tire pressure (information is on the tire cover),
- and if necessary the brake pressing bolt.

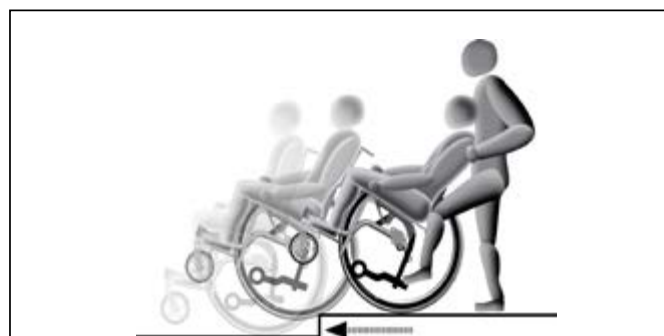
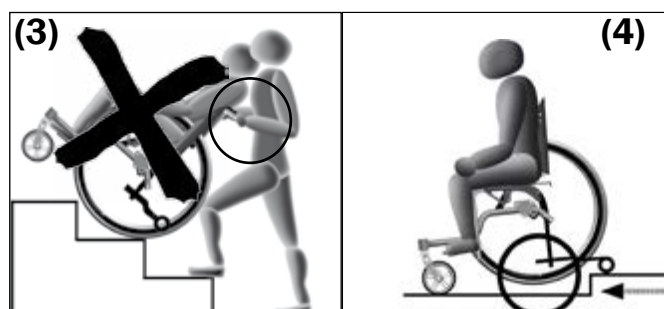
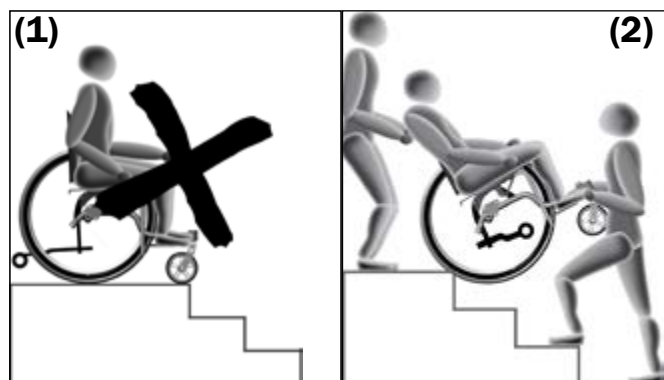

⚠ ATTENTION

Cable controls are high maintenance! The clamp screws on the Bowden cable need to be checked on a regular basis and retightened if necessary.

Check the functional efficiency of all brakes regularly! The wheelchair with occupant (max. load capacity) must stand still on a ramp with a 7° (= 12,3 %) incline with the brake in use.

⚠ ATTENTION

Dirt, wetness, ice, snow, mud etc. can impair the brake force of the wheel lock.

⚠ ATTENTION

Do not carry out repair work on the wheel lock yourself. Ask your rehab technician.

2.6 ANTI-TIPPER

⚠ ATTENTION

We recommend inexperienced and young users to use the anti-tipper whenever possible.

⚠ ATTENTION

Deactivate the anti-tipper in order to overcome height differences, when using elevators or lifting platforms.

(1+2) In order to activate the anti-tipper secure the wheelchair from rolling away, push the step (A) of the anti-tipper down and turn it 180° on its own axis until it snaps into place.

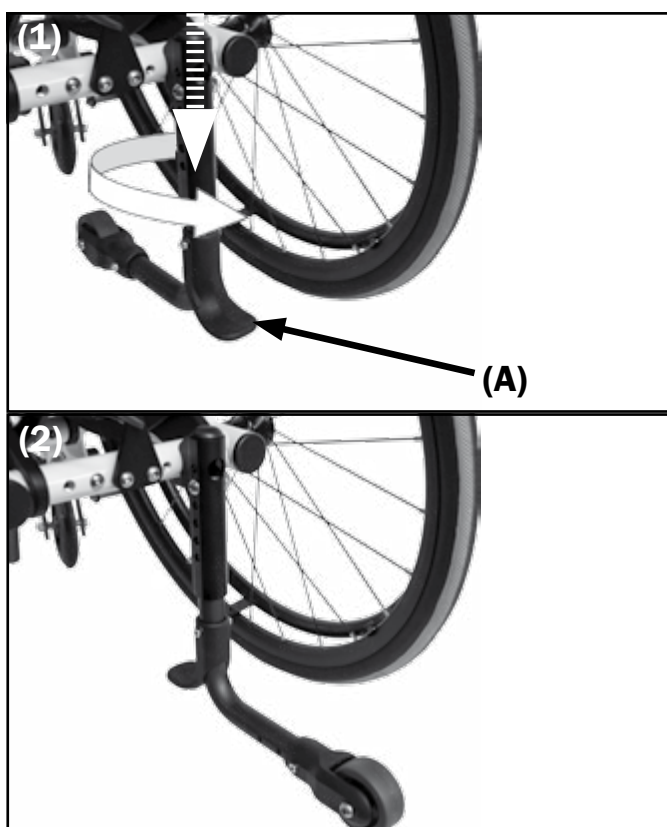

2.7 CASTERS

⚠ ATTENTION

Casters which are not correctly adjusted or driving too fast, especially downhill, can cause the casters to dangerously flap back and forth.

▶▶ INDICATION

Clean the axles and the axle holders regularly, removing lint and dirt.

ℹ INFORMATION

After every change on the driving wheels the casters must be newly adjusted. Have this done by an experienced rehab technician.

▶▶ INDICATION

When transferring in and out of the wheelchair turn the casters forward by driving backwards a little, in order to ensure more stability.

2.8 LOADING AND TRANSPORTING

For the transport of your wheelchair in a car please consider the following points:

- If necessary flip the anti-tipper inwards.
- Fold the back down.
- Unlock the wheel lock and remove the driving wheels.
- Secure the wheelchair with tension belts in the vehicle.
- The tension belts can only be secured on fixed frame parts. Foot rests, side guards, back or seat adapters are not suitable for this.
- Secure all removed parts of the wheelchair in the vehicle so that they cannot hurt anyone in case of sudden braking.

⚠ ATTENTION

There is a risk of getting hurt from loose, flying objects such as leg supports, seat shells, wheels, sticks, bags etc.

Inform yourself by your car salesman about safely securing the wheelchair with lashing eyes or other suitable safety measures in your vehicle before transporting the wheelchair.

2.8.1 Transport in public transportation

In every public transportation a spot must be provided to place the wheelchair according to the EG-guideline 2001/85/EG.

ATTENTION

The spot in public transportation is only arranged for EMPTY wheelchairs.

ATTENTION

Place the wheelchair in the provided area opposite the driving direction so that the backrest and a side guard rest securely on the edge of the provided area.

- The wheelchair should not shift in case of an accident.
- Close the wheel lock.
- During the drive leave the wheelchair and seat yourself in the provided seat next to the spot for your wheelchair.
- If available, use the seat belt!

Let someone help you get in and out of public transportation,

- so that you do not get stuck in the crack between the door and the sidewalk,
- so that you can be helped getting into the seat and tying down the wheelchair.

2.8.2 Transport in other vehicles

Wheelchairs can never reach the stable features of a firmly mounted car seat because of their purpose and light build.

ATTENTION

THUS, WE RECOMMEND YOU TO NOT USE THE WHEELCHAIR AS A SEAT WHILE TRANSPORTING IN A VEHICLE.

READ

Read our info brochure “Crash Test ISO 7176-19”. Here, the potential dangers and regulations of the ISO 7176-19 are described.

ATTENTION

Only wheelchairs that have successfully passed a dynamic crash test according to ISO 7176-19 are allowed to be used as a seat in a vehicle.

Our successfully tested wheelchairs are provided with this international symbol on the type sign and are additionally marked on our order form with our “crash test button”.



If necessary, inform yourself by your retailer or under www.sorgrolls-tuhltechnik.de, if your model is approved as a seat in a vehicle.



2.9 OTHER RISKS

►► INDICATION

Avoid direct sunrays. Dark parts on the wheelchair can heat quickly and can possibly cause burns.

ATTENTION

FIRE RISK from the textile parts (seat shell and back covering, seat cushion or plastic parts). Keep sources of ignition away from the wheelchair.

ATTENTION

Hand rims heat up from strong friction especially from braking while driving fast or from driving downhill for a while.

►► INDICATION

For sensitive skin we recommend to wear gloves as used for cycling (finger stalls with a leather inner surface—but NEVER wool gloves).

ATTENTION

RISK OF HAND INJURY from turning parts. Do not grab in between the spokes of the driving wheel or between the rear wheel and the knee lever brake.

ATTENTION

Do not use the wheelchair in damp rooms or drive in salt water with it. Important parts may corrode and not work properly anymore, whereby the driving quality or the lifespan of the wheelchair are negatively influenced.

3 Handling

3.1 ASSEMBLY GROUP WHEELS

3.1.1 Quick release axle wheels

(1) To release or apply the quick release axle, push the locking knob (A) in the middle of the wheel hub, pull the wheel out of the fitting (B) and release it after the action.

⚠ ATTENTION

(2) AFTER APPLYING, THE LOCK BALL (A) MUST STICK VISUALLY STICKING OUT OF THE FITTING (B) AT THE END OF THE QUICK RELEASE AXLE.

Be sure to regard the following points:

- Wheels are rotating parts and can cause injuries to fingers.
- After replacing the wheels, check the secure hold of the quick release axle! The wheel should not be able to be removed.
- (2) Check the locking knob (A) (tension spring) regularly to make sure it functions properly.

3.1.2 Drum brake wheels

To apply/remove, please proceed as described above.

⚠ ATTENTION

The drum brake wheels' brake pads are extremely sensitive and can lose their functionality from dirt or scratches on the brake pads. Remove lint and dirt from the brake pads regularly with a soft brush. Check the functionality of the Bowden cables regularly, in short intervals.

(3) To brake the drive, the assisting person pushes both brake levers (A).

⚠ ATTENTION

Uneven pressure causes swerving.

(4) To secure the wheelchair

- pull both levers (A) up and snap the small locking levers (B) in the grooves (C).
- The drum brake is now blocked.

To release the lock

- pull both levers (A) a little bit further up, until the small locking levers (B) are unlocked and
- after release the levers (A).

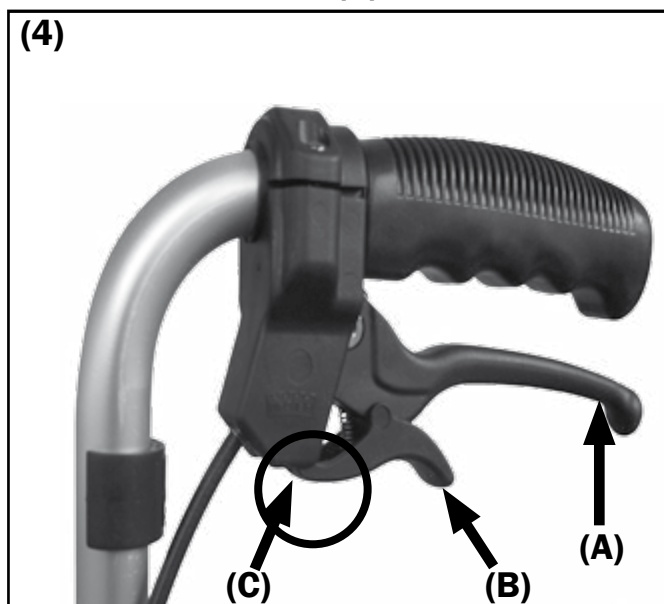
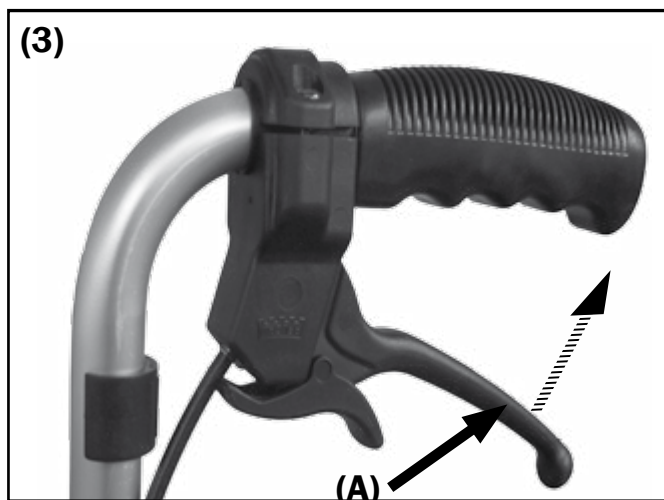
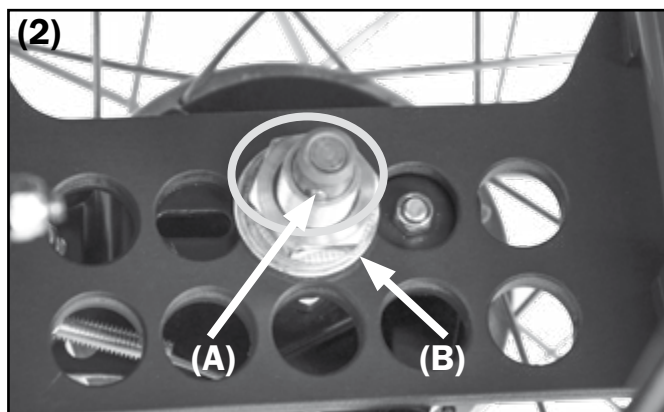

3.1.3 Casters

⚠ ATTENTION

At the first sign of the casters „flapping“ (especially when driving fast or on downhill) slow the wheelchair down immediately!

⚠ ATTENTION

Regularly remove lint and dirt from the caster axles, forks and quick release axles.

For **casters with exchange rate** please proceed as with the quick release axles of the driving wheels.

Track fixation

Locking/unlocking

(1) Picture 1 shows the track fixation **unlocked**.

To **lock** pull the locking bolt (A) a little bit forward, turn it 90° and let it slide into the guiding slot (C).

To **unlock** proceed analog.

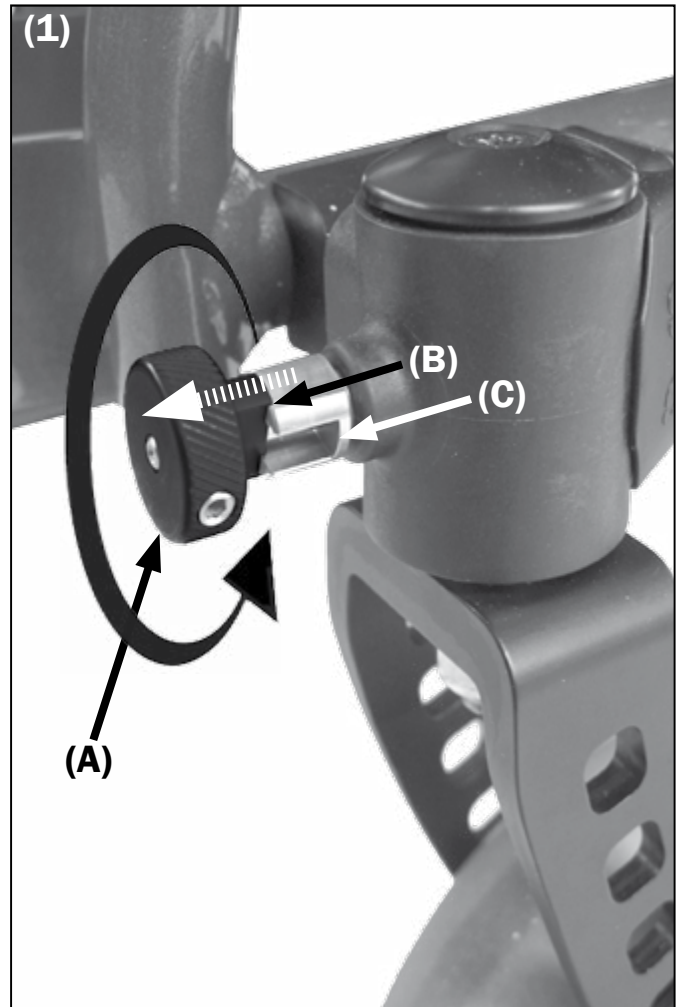

3.2 SPECIAL HAND RIMS

3.2.1 Double hand rim

Familiarize yourself, with the help of an experienced helper and in familiar surroundings, with the technology of this particular way of driving.

⚠ ATTENTION

AFTER PUTTING ON THE WHEELS THE LOCK (1B, 2C) MUST BE ACTIVATED. THE WHEELS SHOULD NOT BE ABLE TO COME OFF.

⚠ ATTENTION

To brake you must apply the same pressure to the hand rims (inside and outside), otherwise you will swerve unwillingly and become a hazard to yourself and your surroundings.

⚠ ATTENTION

Especially when driving downhill, make sure that you are able to bring your wheelchair to a stop at any time or have someone help you.

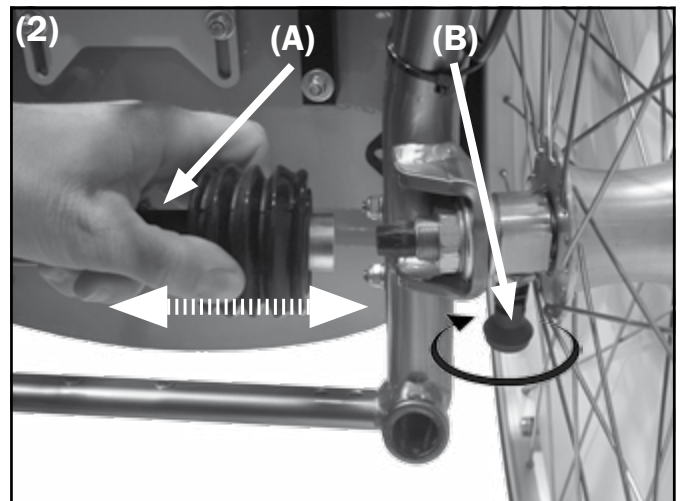

(2) To **remove** the wheels with a double hand rim:

- Push the telescope tube (A) together on both ends
- and unlock the rear wheels.
- Turn the latch (B) 90° and remove the wheels.

(3) To **put on** the wheels with a double hand rim:

- Place the axle (A) in the fitting (B).
- Lock the wheels with the latch (C).
- Press the telescope tube together and
- place the ends (D) on the axle (A).

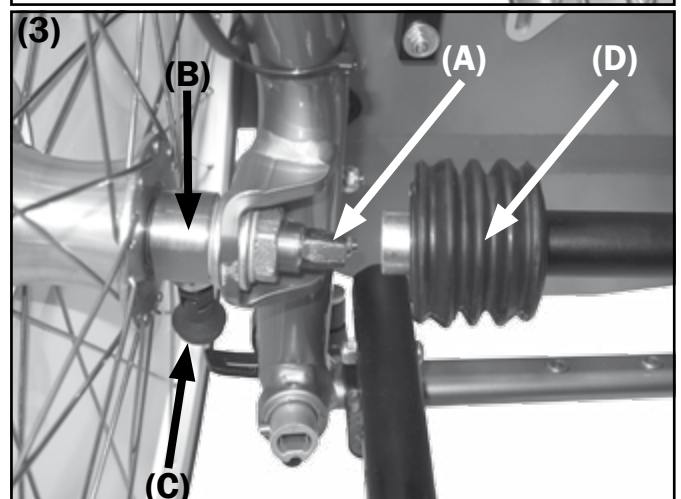

3.2.2 Knob hand rims

⚠ ATTENTION INJURY RISK!

Regard that the knob hand rims turn when you are being pushed!

⚠ ATTENTION

Braking with pressure on the hand rims is not possible. This applies especially when driving downhill. Let an experienced and strong carer assist you.

3.2.3 Hand rim covers / Maxgrepp hand rims

⚠ ATTENTION

All hand rim covers and the Maxgrepp hand rims are made of several black synthetic materials and can heat to over 42° in the sun!

⚠ ATTENTION

Under unfavorable circumstances the black coatings can stretch from heat and can detach from the hand rim. Avoid direct sunrays.

3.3 SEAT-BACK UNIT

⚠ ATTENTION

WITH THE ANGLE ADJUSTMENT OF THE SEAT-BACK UNIT (TILTING) AND/OR THE BACK >90°, THE CENTRE OF GRAVITY AND THE TILTING BEHAVIOR OF THE WHEELCHAIR CHANGES DISTINCTLY.

⚠ ATTENTION

THE BACK AND THE BACK-SEAT UNIT CAN ONLY BE ADJUSTED OR TILTED TO >90° WITH LOCKED BRAKES AND ON AN EVEN, FIRM SURFACE. NEVER OPERATE THE TILTING MECHANISM DURING THE DRIVE.

⚠ ATTENTION

BEFORE EACH TILTING OF THE SEAT-BACK UNIT ACTIVATE THE ANTI-TIPPER AND SECURE THE WHEELCHAIR FROM ROLLING AWAY.

⚠ ATTENTION

With a tilted wheelchair and/or a back angle >90° a suitable support for the head must be provided (head rest or submersible back extension).

⚠ ATTENTION

Do not hang anything (bags etc.) on the push bail; especially not in a tilted position and/or a back angle >90°.

3.3.1 Tilting

To activate the tilting:

- (1+2) pull the lever (A) and
- hold it until the desired position is reached.
- Then release it.
- To adjust the push height, adjust the angle of the push bail after (B).

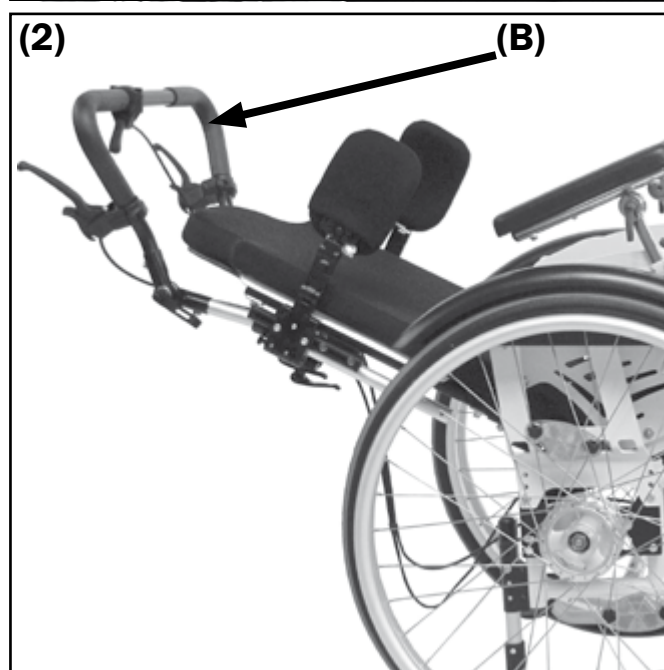
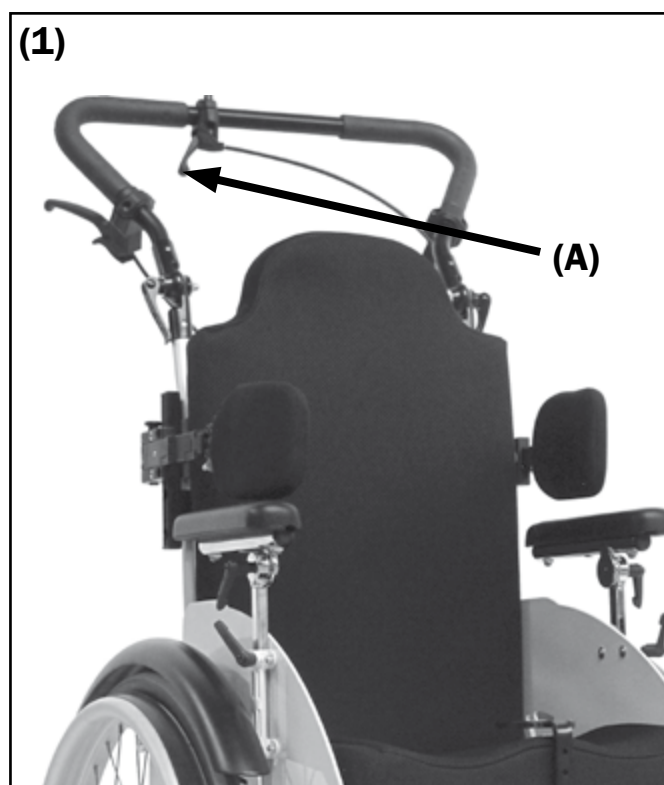

3.3.2 Adjusting the back angle

(1) To adjust the back angle:

- With the cord **(A)** pull the bolts **(B)** out of the row of holes **(C)** on both sides, so that the bolts **(B)** unlock on both sides.
- Hold the cord **(A)** while adjusting.
- Slide the back along the row of holes **(C)** to the desired position.
- Release the cord **(A)** so that both bolts **(B)** can click into place in the wanted bore of the row of holes **(C)**.

⚠ ATTENTION

After every back angle adjustment make sure that **BOTH** bolts **(B)** are locked in tightly in the bores of the row of holes **(C)**!

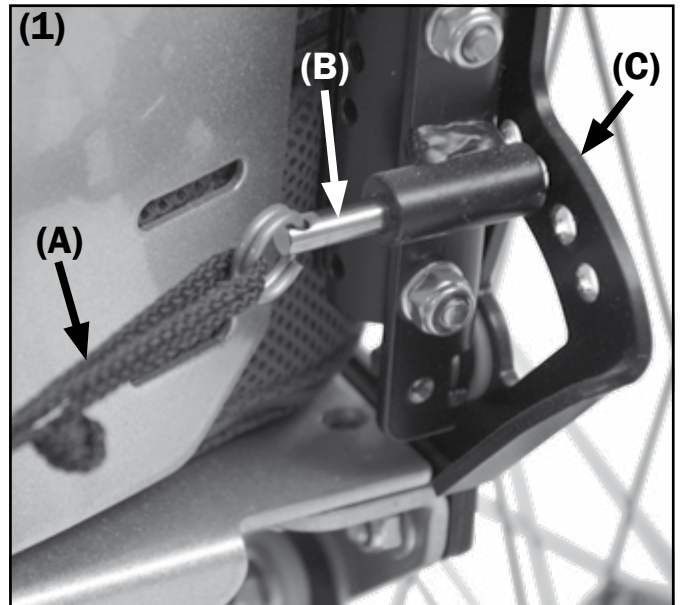

3.3.3 Folding the back down

To fold down:

- Proceed as described above and fold the back down to the front.

►► INDICATION

In order to make the wheelchair more compact for transport fold the push bail forward after and remove the wheels.

To restraighten the back:

- Fold the back back and at the same time pull with the cord **(A)** the bolts **(B)** inward, so that they can glide past the row of holes **(C)**.
- Release the cord **(A)** so that the bolts **(B)** can click into the row of holes **(C)** on both sides, in the desired angle.

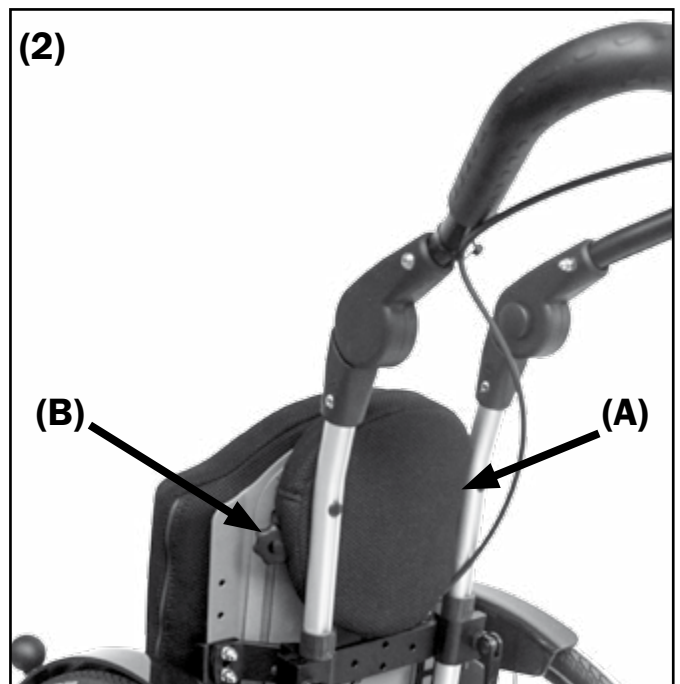

3.3.4 Submersible back extension

⚠ ATTENTION

THE SUBMERSIBLE BACK EXTENSION IS NOT SUITABLE AS A HEAD REST IN A VEHICLE!

(2+3) To extend the submersible back:

- Remove the head cushion **(A)**,
- loosen the star knob screws **(B)** on both sides,
- pull the back extension **(C)** evenly (without tilting!) up,
- retighten both star knob screws **(B)** and
- attach the head cushion **(A)** on the front side of the back extension **(C)**.

To submerge the back extension proceed correspondingly.

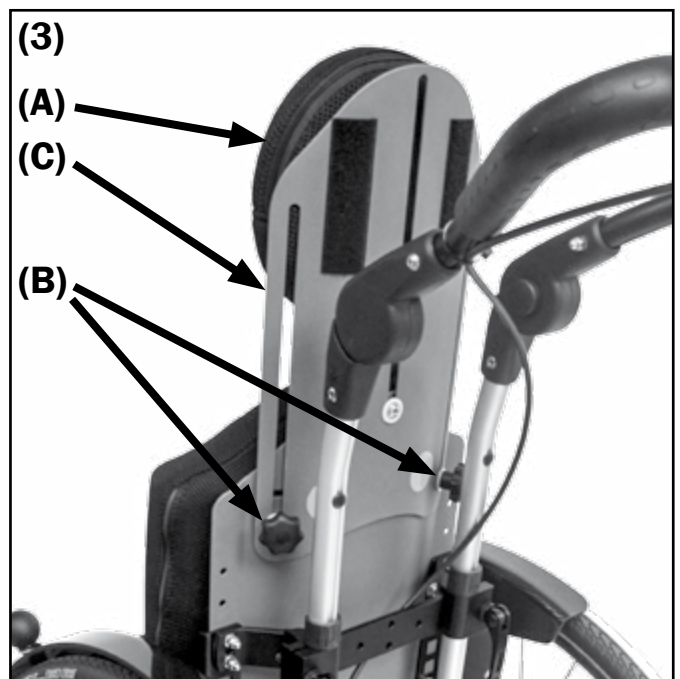

3.3.5 Adjusting the back angle with a gas pressure spring

⚠ ATTENTION

WITH THE ANGLE ADJUSTMENT OF THE BACK $>90^\circ$ THE CENTRE OF GRAVITY AND THE TILTING BEHAVIOR OF THE WHEELCHAIR CHANGES DISTINCTLY. THUS, NEVER CHANGE THE BACK ANGLE WHILE DRIVING.

⚠ ATTENTION

With a back angle $>90^\circ$ a suitable support for the head must be provided. (head rest or submersible back extension).

(1) To adjust the back angle with a gas pressure spring:

- Press both levers (A) and hold them until you have brought the back in the desired position.
- Then release the levers.

3.3.6 Folding the back angle down with a gas pressure spring

(2) To fold the back down to the front:

- Secure the wheelchair from rolling away.
- Press the small red button (A) on the locking bolt (B),
- at the same time pull the bolt (B) completely out of the carrier (C).
- Fold the back forward.

(2) To restraighen the back:

- Pull the back back into a vertical position.
- Place the locking bolt (B) in the bore of the carrier (C) until the springs (D) stop.
- Guide the release button (E) of the gas pressure spring into the carrier (C).
- Press the red button (A) of the locking bolt (B) (the springs (D) glide inward) and
- put the bolt (B) completely through the carrier (C) and through the bore (F) of the release (E).
- Proceed correspondingly on the opposite side.

⚠ ATTENTION

(3) After using the release (E) of the gas pressure spring the spring (D) of the locking bolt (B) must be visually sticking out on the outer side of the carrier (C).

OUTHERWISE THE WHEELCHAIR IS NOT USABLE.

Make sure that the locking bolts (B) cannot be taken out.

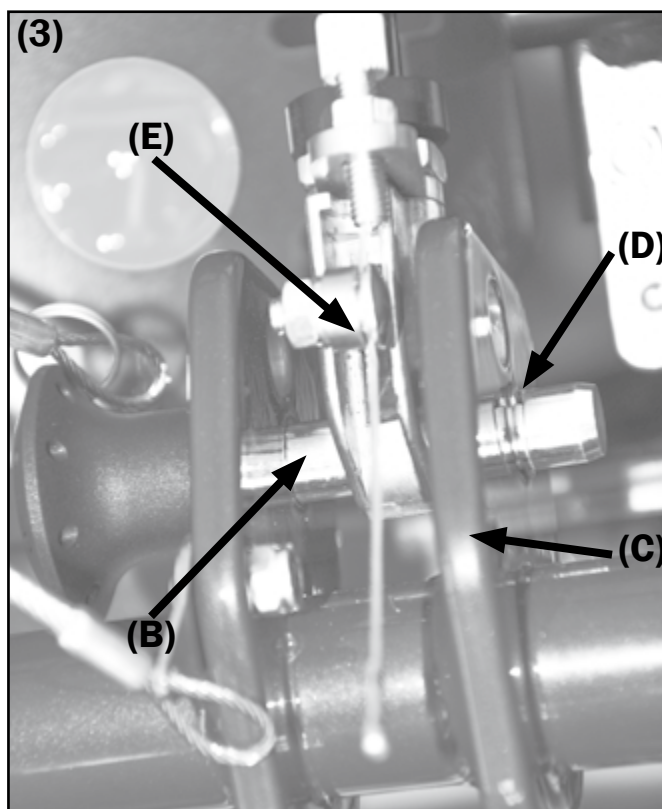
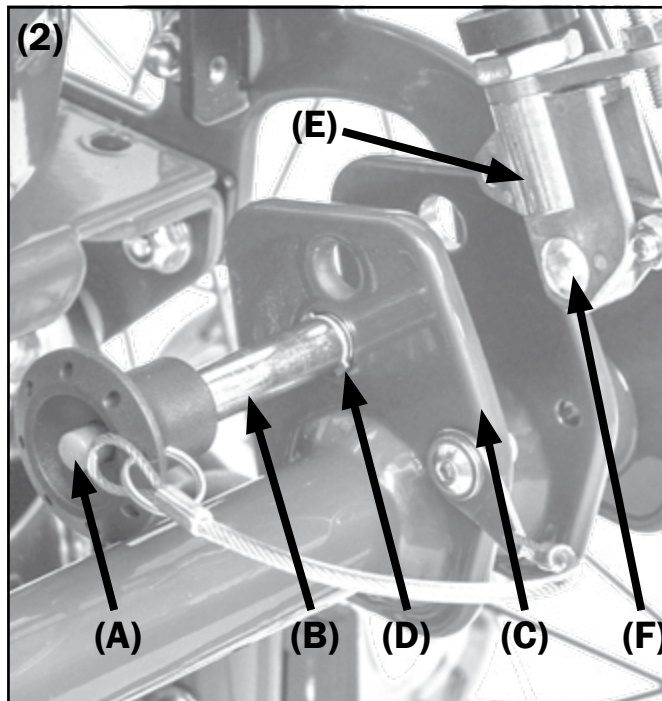
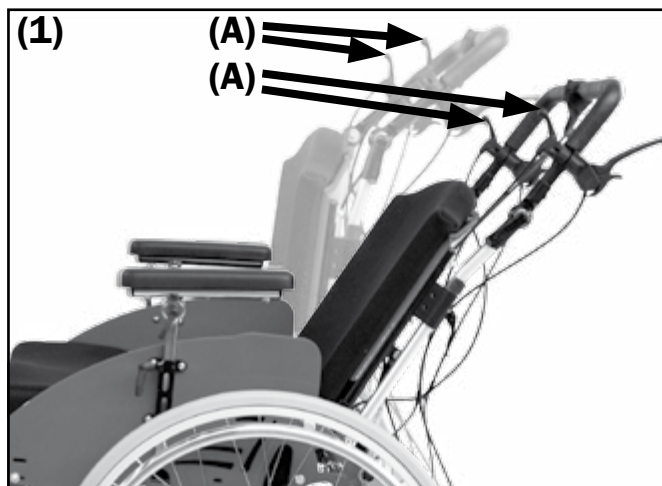

3.4 PUSH AIDS

(1) For all various push aids (push bails, handle/s) please regard:

⚠ ATTENTION
ALL PUSH AIDS ARE ONLY THERE TO PUSH THE PERSON ON THE WHEELCHAIR - NOT TO CARRY THEM!!!

⚠ ATTENTION
THE SPRING (1B) MUST ALWAYS BE VISIBLY STICKING OUT OF THE HOLES AT THE BOTTOM OF THE HOLDER (1C).

⚠ ATTENTION
Picture (3) shows the tube BEFORE inserting in to the holder! THE WHEELCHAIR IS NOT USEABLE WITH THE PUSH BAIL IN THIS POSITION!

⚠ ATTENTION
The eccentric clamps (1A) can loosen under adverse conditions. Before overcoming each obstacle, be sure to check them to make sure they are tightly closed.

⚠ ATTENTION DANGER OF TIPPING OVER
Do not hang any objects (bags etc.) on the push aids!

⚠ ATTENTION
(2) The curves at the end of the eccentric clamp (A) must always be concise with the half shell (B). The proper functioning is not guaranteed if the eccentric clamp (A) is not concise with the half shell (B).

▶▶ INDICATION
(3) The holder (A) of the push handle tubes (B) is provided with an inner profile (C) that is consistent with the profile (D) of the tubes (B). With this, the tubes (B) can only be guided into the holder (A) one way and are secure from turning.

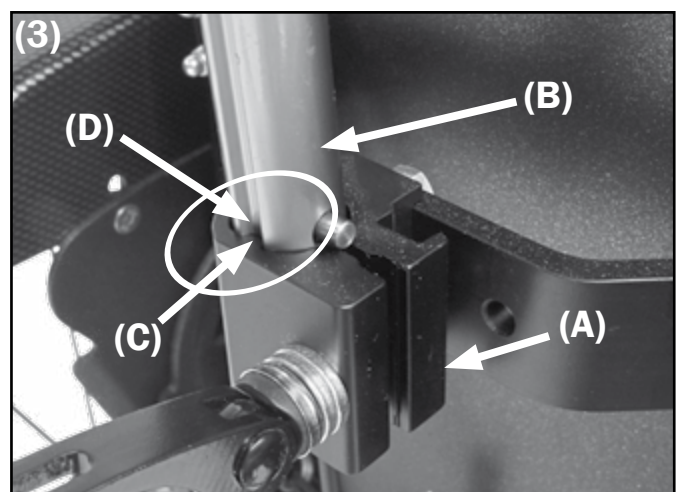
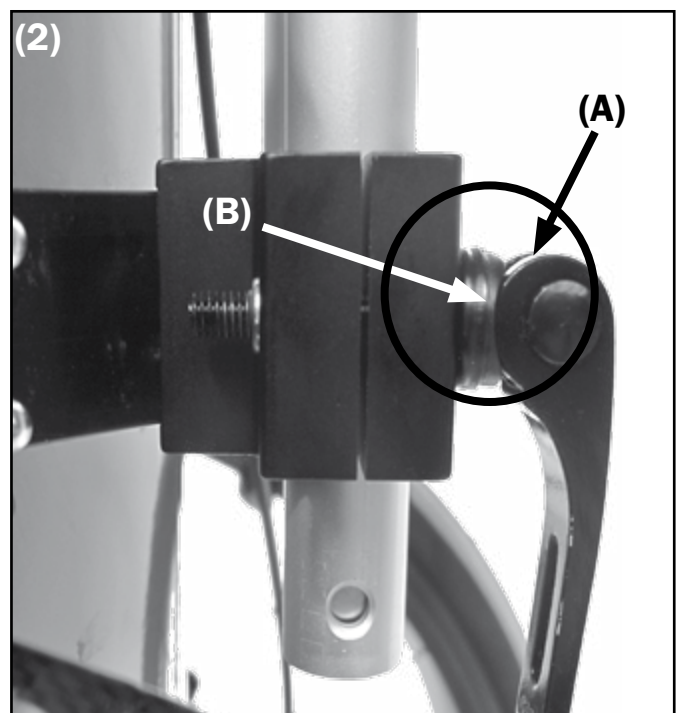
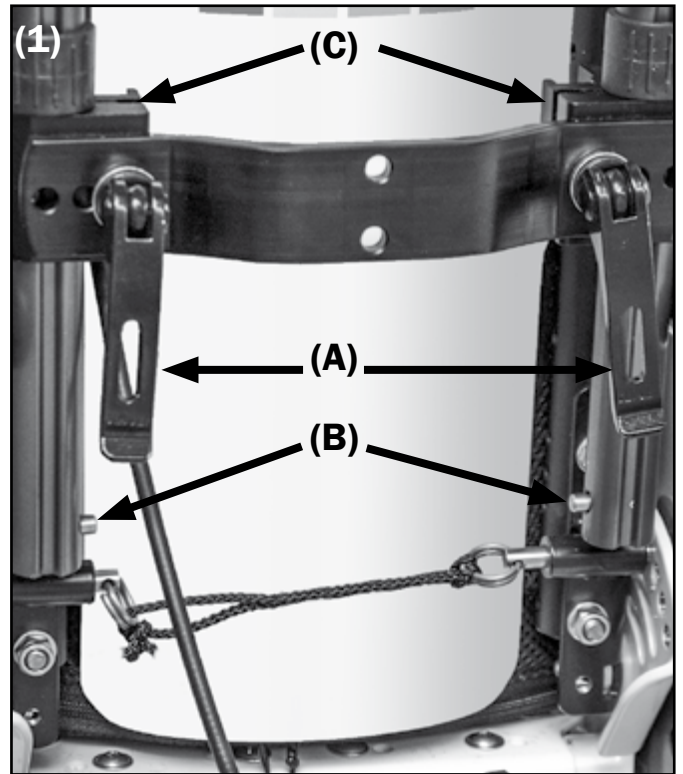

3.4.1 Push handles/push bail

For all types of push aids proceed correspondingly.

(1+2) Height adjustment:

- Open the eccentric clamps **(A)**,
- place the push bail/handles **(B)** in the wanted position
- and close the eccentric clamps **(A)** completely.

(3+4) Putting on:

- Open the eccentric clamps **(A)**,
- press the spring **(C)** inward and
- insert the tube **(B)** into the holder **(D)**.
- **(3)** After inserting, the spring **(C)** must visually stick out of the tube on the bottom side of the holder **(D)**.
- Close the eccentric clamps **(A)**.

ATTENTION

The curves at the end of the eccentric clamp **(A)** must always be concise with the half shell **(E)**. The proper functioning is not guaranteed if the eccentric clamp **(A)** is not concise with thtte half shell **(E)**.

(1-4) Removing:

- Open the eccentric clamps **(A)**,
- slide the tube **(B)** as far up until the spring **(C)** hits on the bottom side of the holder **(D)**,
- push the spring **(C)** as far in so that it can glide through the holder **(D)** and
- pull the push bail/handles up out of the holder **(D)**.

ATTENTION

Regard the safety instructions in chapter 3.5.

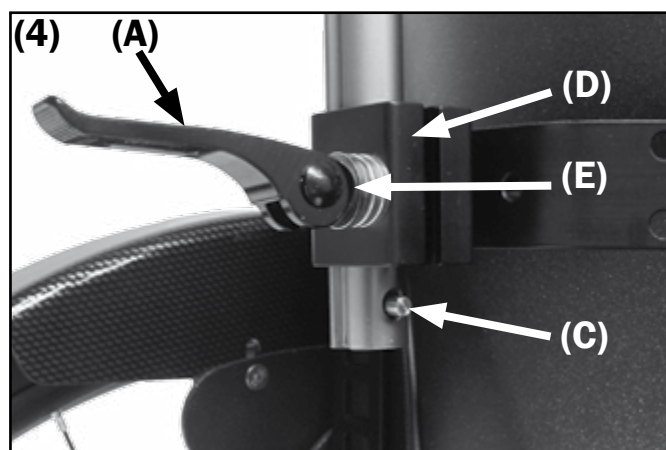
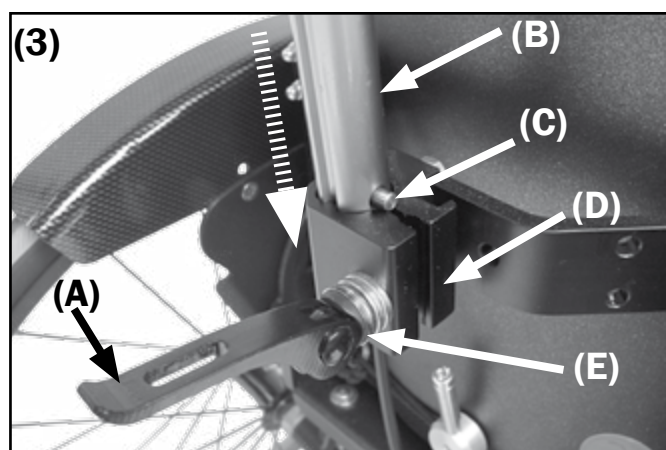
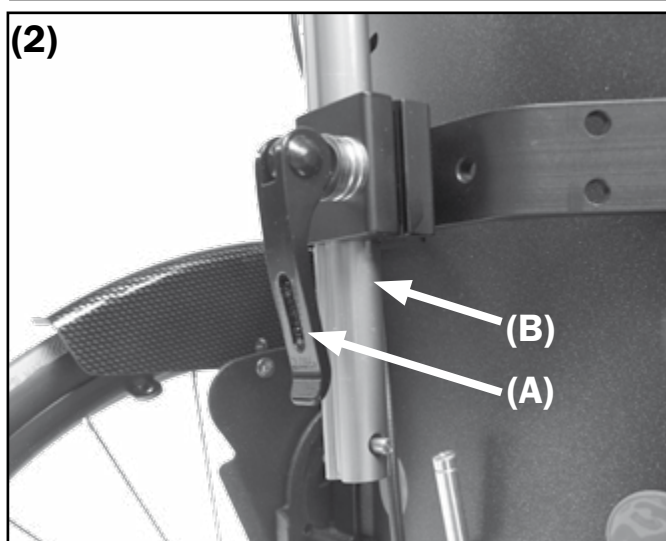
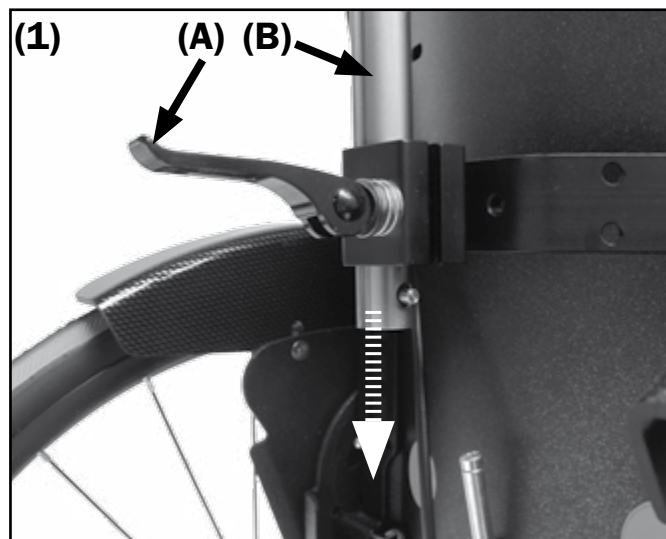

3.4.2 Clamping force of the eccentric clamp

(1) The eccentric clamp (A) is fixated on the opposite side of the holder (D) with a safety nut (E). By turning the eccentric clamp (A) its clamping force changes.

(1) Setting the clamping force

- Open the appropriate eccentric clamp (A),
- correct the clamp force by turning the eccentric clamp on its own axis:
 - clockwise = tightening
 - counterclockwise = loosening,
- close the eccentric clamp (A) and check for proper functioning.

⚠ ATTENTION

The push aids should not be able to move in the holder (D) when the eccentric clamp/s are closed.

⚠ ATTENTION

Check for proper function of the eccentric clamps and the spring (C) in short intervals.

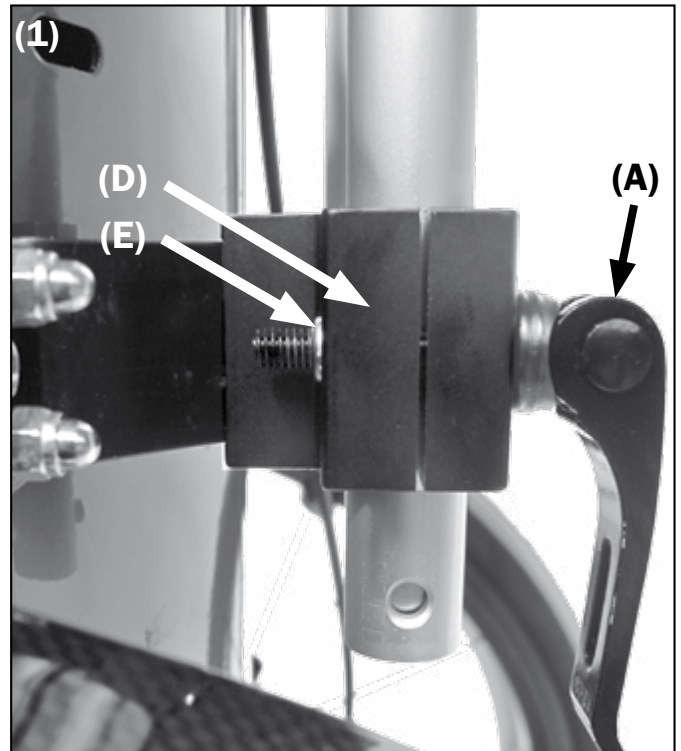

3.4.3 Angle adjustment push bail

Picture (2) shows the opened eccentric clamp, picture (3) the closed one.

(2+3) To adjust the angle:

- Loosen the eccentric clamp (A) on both sides so that the tooth profile (B) of the joint can move freely.
- Place the push bail in the desired position and
- close the eccentric clamp (A).
- Be sure that the tooth profile (B) of the joint are closed tightly.

⚠ ATTENTION

The curve at the end of the eccentric clamp (A) must always close tightly with the half shell (E). If the eccentric clamp (A) is not tightly closed with the half shell (E), then the proper functioning is not guaranteed.

⚠ ATTENTION

Regard the general safety instructions.

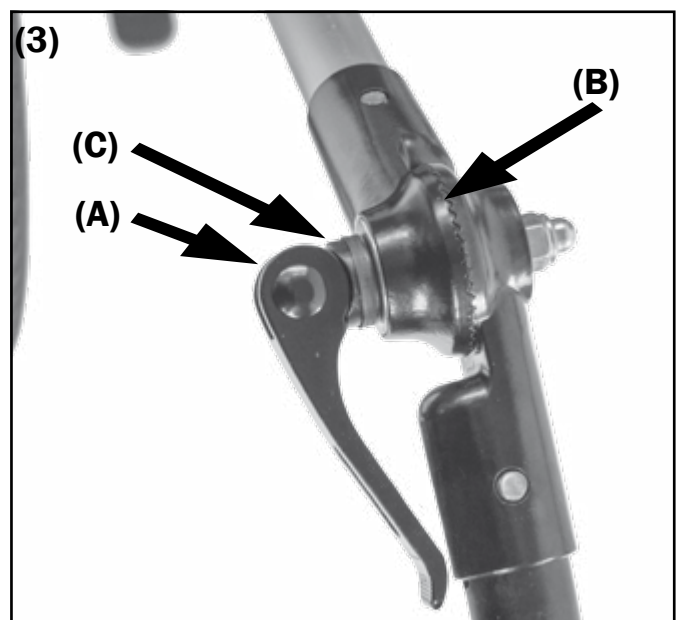
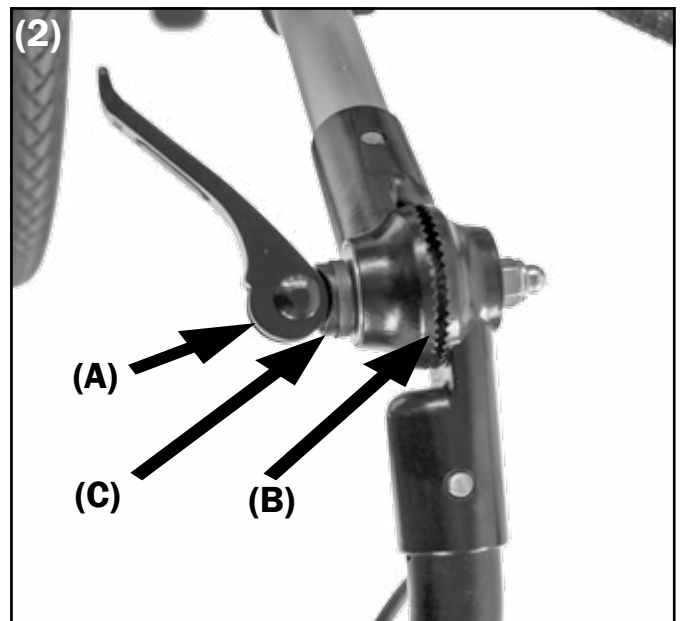

3.4.4 Push aid for outside (Outdoor Front End)

⚠ ATTENTION DANGER OF FLIPPING OVER

(1) Please regard that by mounting the push aid the centre of gravity of the wheelchair changes and the danger of flipping over is increased.

⚠ ATTENTION DANGER OF FLIPPING OVER

During the mounting process, the wheelchair user must be secured from tipping backward - the best way is from the help of a second carer.

If possible, the user should lean their upper body forward as far as possible during mounting.

⚠ ATTENTION

A great amount of caution is to be taken when driving with a tilted seat and going up or downhill.

⚠ ATTENTION

The push aid is built for a max. speed of 8 km/h. A higher speed is not allowed.

⚠ ATTENTION

Have all work to extend/widen the push aid done by your rehab technician.

Mounting the push aid

- (2) Place the wheelchair with the casters on a jack up aid (A),
- secure the wheelchair from tipping backward
- and close the wheel lock.
- Put the latches (B) on both sides in an opened position as shown in picture (3b) (pull out and turn 90°)
- and insert both bars (C) from the front all the way into the adapter (D).
- (3a+b) Die Arretierungsbolzen (E) müssen auf beiden Seiten bis zum Anschlag in den Aufnahmeadapter (D) eingeführt sein.
- Close the latches (B) (they need to snap into place on both sides)
- and remove the jack up aid (B).

⚠ ATTENTION

After mounting, be sure to check the firm fit of the push aid in the adapter and that it is locked.

Removing the push aid.

To remove, proceed in reverse order.

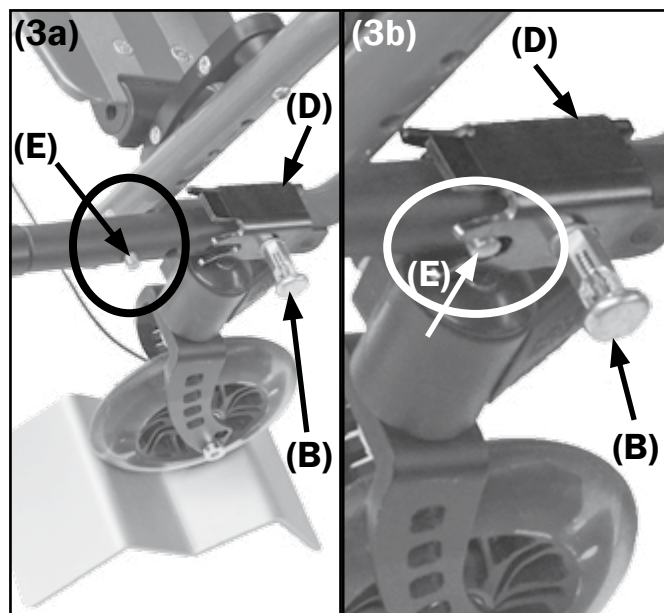
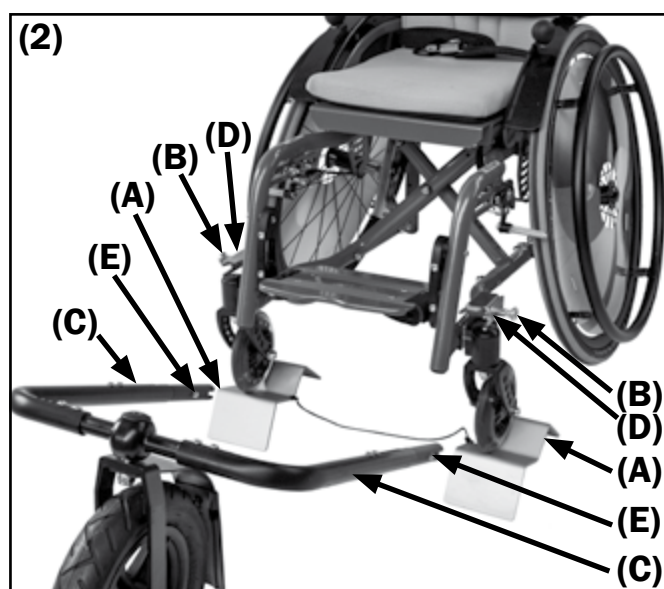
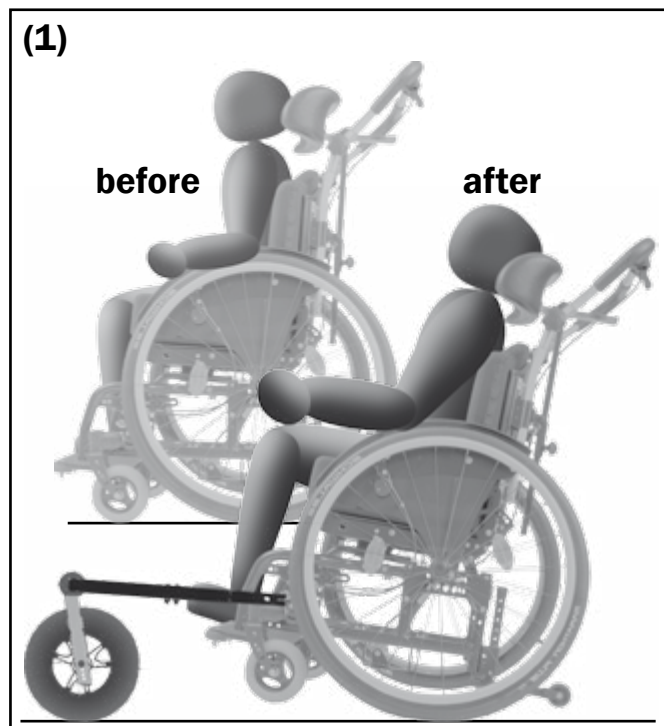

3.5 LEG SUPPORTS

⚠ ATTENTION

NEVER LIFT/CARRY THE WHEELCHAIR BY THE FOOTREST WHEN SOMEONE IS IN IT.

(1) All leg supports can be adjusted:

- the horizontal distance to the seat,
- the vertical distance between upper edge seat and foot plate (= lower leg length)
- and the angle of the foot plate.

▶▶ INDICATION

Have these settings done by a qualified rehab technician!

To get in and out easier:

- Secure the wheelchair from rolling away and
- fold the foot plate/s back.

3.5.1 Locking and unlocking the foot plate/s

(2+3) To unlock:

- Pull the latch **(A)** out of the slot **(B)**,
- turn it 90°
- and release the latch so that it stays unlocked.

To lock:

- Place the foot plate in the locking position,
- turn the latch **(A)** again 90° until it has snapped into the slot **(B)**.

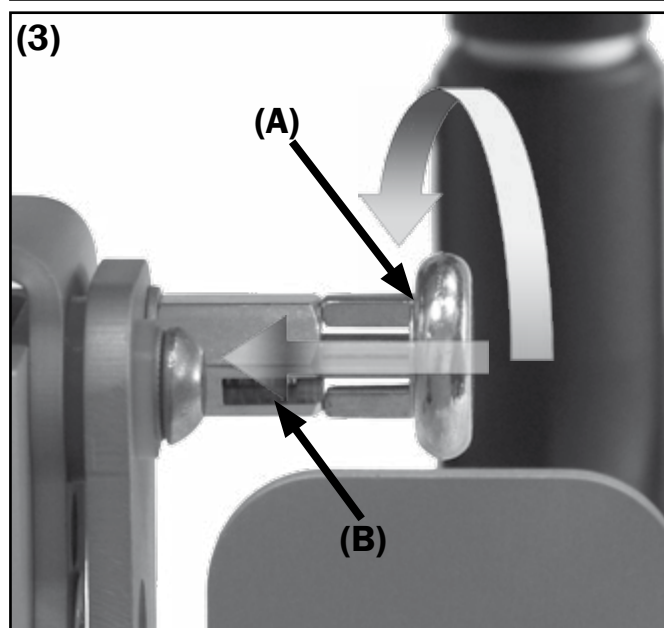
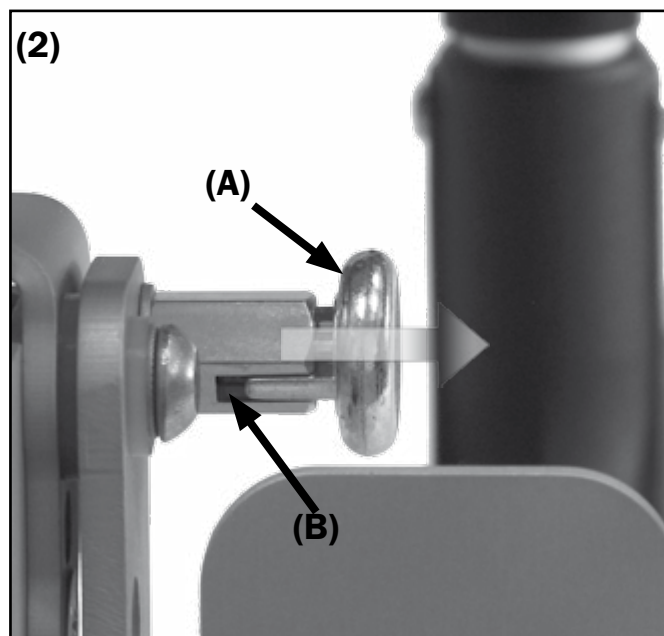

3.5.2 Standard leg support, continuous or divided

To get in:

- Secure the wheelchair from rolling away and activate the anti-tipper!
- If necessary, unlock the foot plate/s and fold them back.
- As soon as the user is safely seated in the wheelchair, lift their legs,
- fold the foot plate/s forward
- and position their feet on the foot plates.
- If possible lock them.

►► INDICATION

For some children it is asked for, therapeutically, that they get in and out on their own by using the footrest. In this case consider the following:

- Secure the wheelchair from rolling away,
- turn the casters forward
- and activate the anti-tipper.
- Never let the child get in and out unattended
- and be ready to give assistance.

(1+2) To change the horizontal distance:

- Loosen the clamp lever/the screws (A)
- and place the adapter tube/s (B) in the desired position.
- Retighten the clamp lever/the screws (A).

(1) To change the vertical distance from seat/foot-plate with model 1:

- Loosen the clamp levers(C)
- and place the adapter tube (D) in the desired position.
- Retighten the clamp levers! (C).

(2) To change the vertical distance from seat/foot-plate with model 2:

- Remove the screws (C)
- and move the foot plate to the desired position (D).
- Replace the screws (C) and retighten them.

(3) To change the angle of the foot plate/s:

- Fold the foot plate (A) back.
- On the inside of the foot plate joint (B) is a setscrew (C).
- If need be, turn the setscrew (C) open or closed: open = angle $<90^\circ$, closed = angle $>90^\circ$.

►► INDICATION

Please note that with an angle $>90^\circ$ the user's feet can slide forward. In this case foot belts can be necessary.

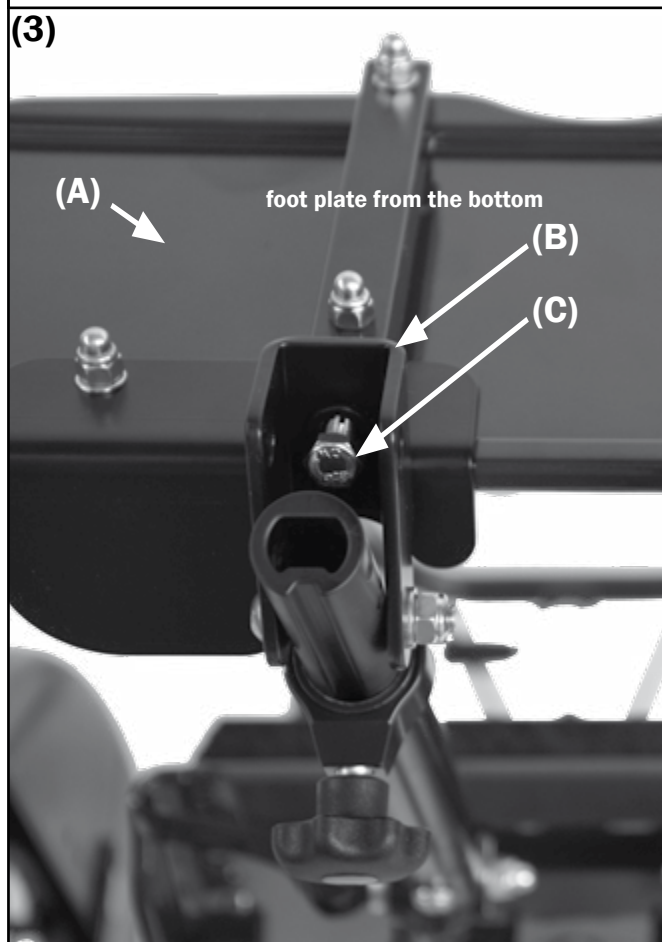
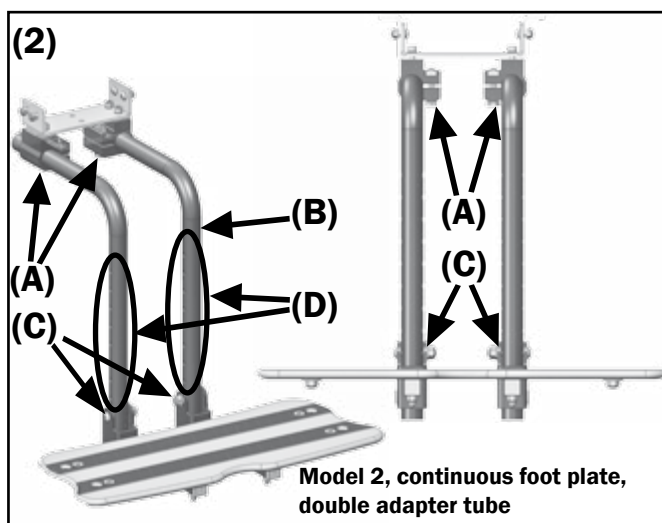
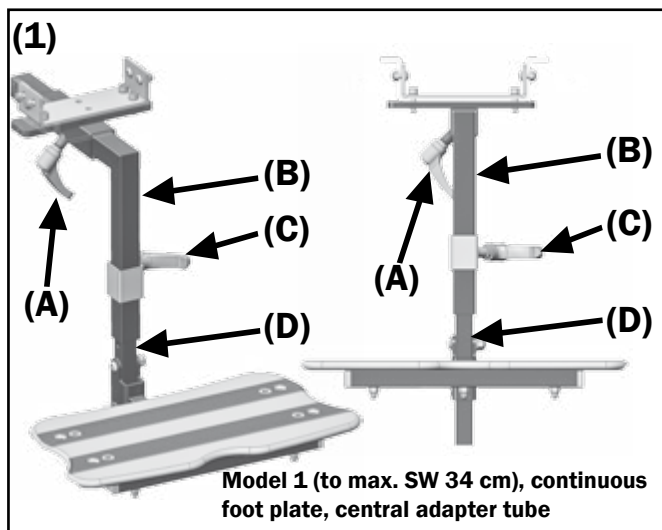

3.5.3 Leg support can be elevated, continuous or divided

(1) To elevate the leg support:

- Secure the wheelchair from rolling away and activate the anti-tipper.
- Pull the ring/s (A) out,
- guide the leg support holder (B) along the 5-hole-raster (C) to the desired position
- and release the ring/s (A) so that they can snap into place.

(1) To change the vertical distance of seat/foot plate:

- Loosen the clamp lever/s (D),
- pull the bottom end of the foot plate holder/s (E) to the desired length
- and retighten the clamp lever/s (B).

(2) Alternatively for a big LLL:

For a big LLL move the clamp lever holder (F) down:

- remove the clamp lever (D),
- move the holder (F) to the bottom holes (G) of the leg support holder (B)
- replace the clamp lever/s (D) back in the holder (F) and tighten it.

►► INDICATION

Please regard that the casters must be able to turn 360° freely under the foot plate or on the side when the wheelchair is not tilted.

(3) To change the angle of the foot plate/s:

- Please proceed as described in the previous chapter.

►► INDICATION

Please note that with an angle >90° the user's feet can slide forward. In this case foot belts can be necessary.

3.5.4 Leg rest

(3) To set the position:

- Loosen the clamp lever (A) on the bottom of the cushion (B), (see picture 3)
- guide the cushion (B) along the holes (D) to the desired position
- and retighten the clamp lever (A).

(3) To set the tilt angle:

- Loosen the nut (C) of the cushion holder on both sides,
- place the cushion (B) in the desired position
- and retighten the nut (C).

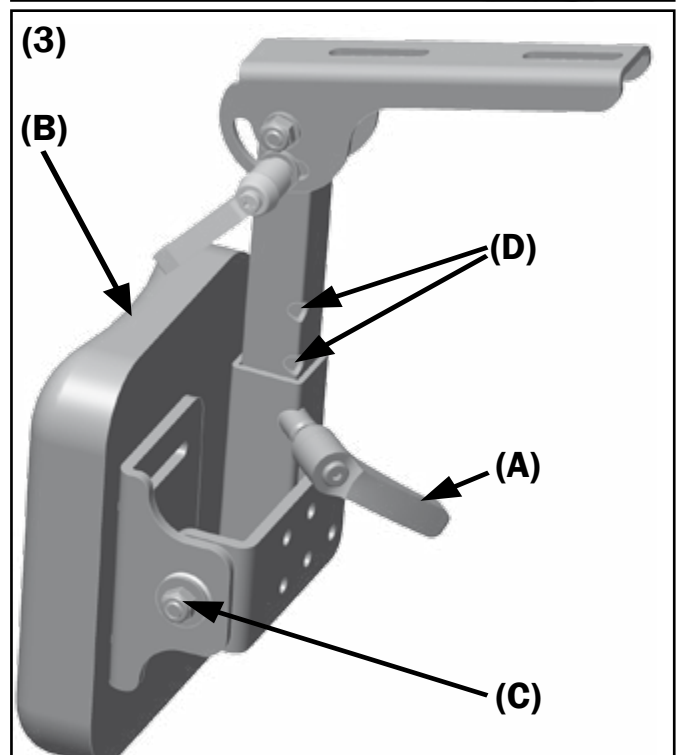
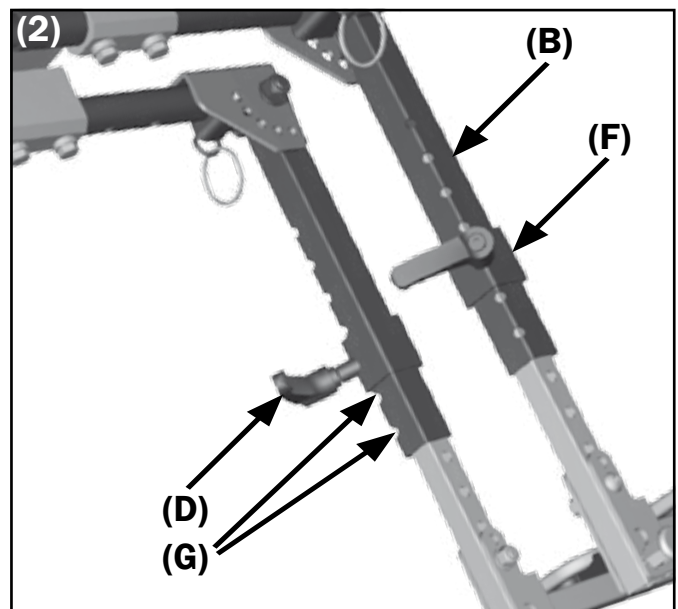
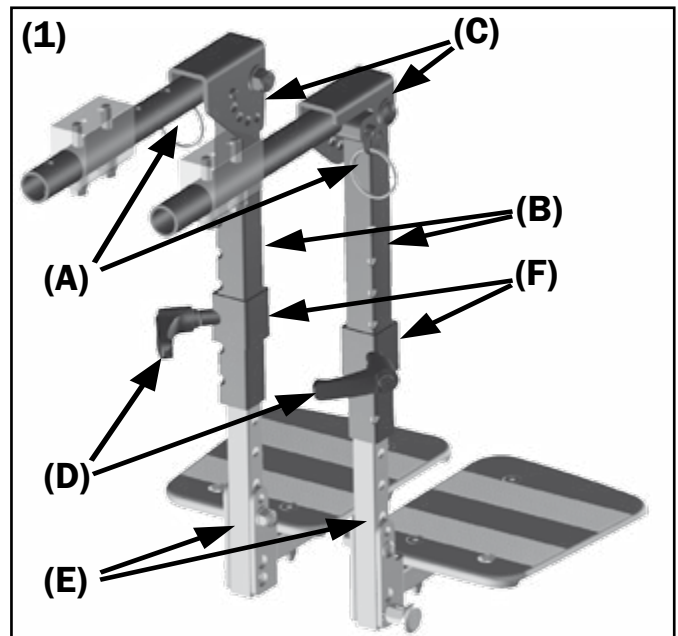

3.6 BRAKES

⚠ ATTENTION

THE KNEE LEVER BRAKES ARE ONLY TO BE USED FOR PLACING THE WHEELS IN A RESTING POSITION. THEY ARE NOT TO BE USED TO BRAKE WHILE DRIVING!

THE WHEELCHAIR IS NOT OPERABLE UNTIL ALL BRAKE MALFUNCTIONS HAVE BEEN FIXED.

⚠ ATTENTION

Possible damages or malfunctions can occur from:

- too low tire pressure,
- wetness, snow, mud etc.,
- worn off profile,
- worn off brake bolts,
- loose screws on the brake bolts
- defected Bowden cable on cable brake or drum brake,
- dirty drum brake,
- a great distance between brake bolts and tire.

⚠ ATTENTION

A wheelchair is generally (when physically possible) slowed down when simultaneous pressure is applied with both hands on the hand rims.

When driving downhill a higher strain for braking occurs. Do not shy away from getting help. Before each ride be sure to check the functionality of the brakes.

The wheelchair with passengers (max. load capacity) must stand safely on a ramp with a slope of 7° (= 12,3 %) when the wheel lock is in use.

3.6.1 Standard wheel lock

(1) To block the wheel lock:

- Press both control levers (A) forward until they snap into the new position and the brake pressing bolts (B) are pressing firmly on the tire cover
- To loosen pull both control levers (A) back.

3.6.2 Cable brake

(2) To block the cable brake:

- Press both control levers (A) forward until they snap into the new position and the brake pressing bolts (B) are pressing firmly on the tire cover.
- To loosen pull both control levers (A) back.

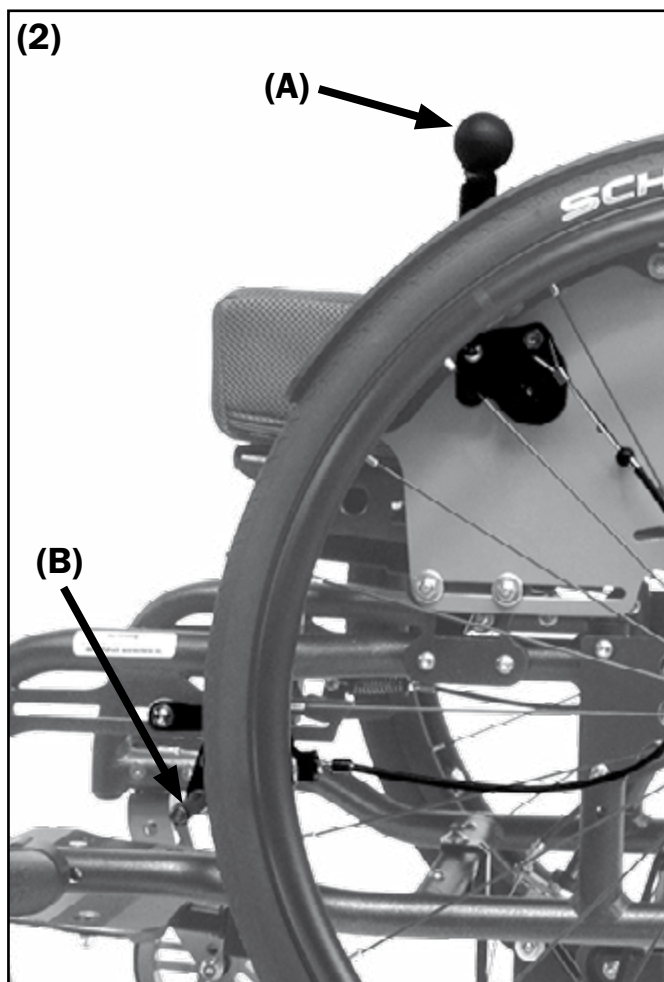
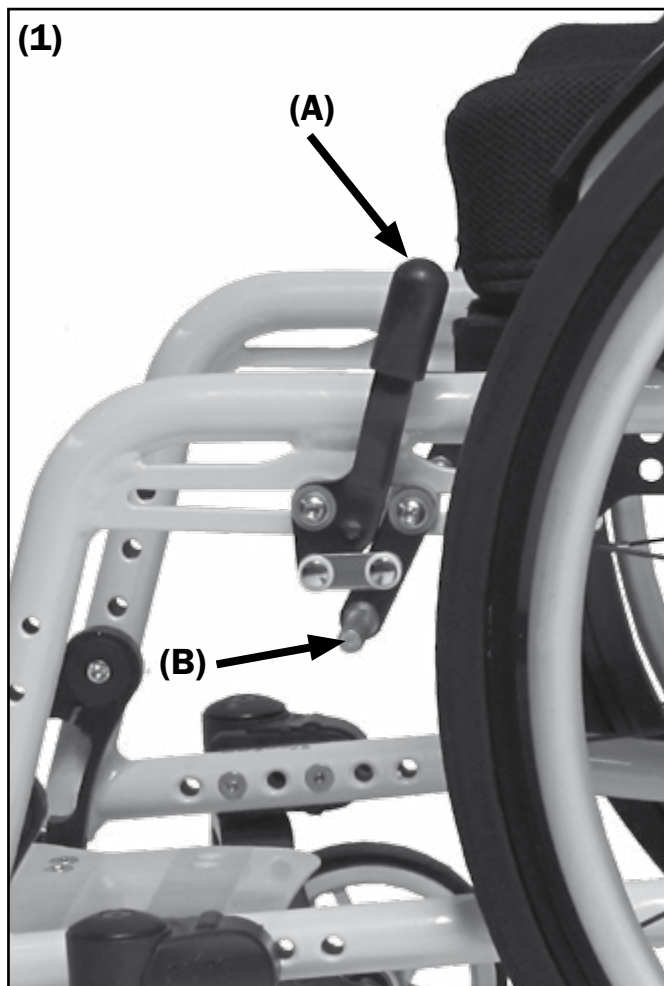

3.6.3 Drum brake as driving brake

The drum brake is suitable for braking while driving.

(1) To brake

- Pull the control lever **(A)** up evenly
- and apply the same pressure to both brake levers **(A)** otherwise you will swerve unwillingly
- **(2)** Only use the blocking lever **(B)** to secure the control levers in a locked position.

⚠ ATTENTION

Avoid braking jerkily while driving: DANGER OF FLIPPING OVER!

3.6.4 Drum brake as wheel lock

(3) To lock the drum brake:

- pull both control levers **(A)** up until the tip of the blocking lever **(B)** has snapped into the grooves **(C)**.
- The control lever **(A)** should not be able to move down.

To unlock:

- Pull the control levers **(A)** up a little further until the blocking levers **(B)** automatically unlock and release the control levers **(A)**.

⚠ ATTENTION

The wheelchair with passengers (max. load capacity) must stand safely on a ramp with a slope of 7° (= 12,3 %) when the wheel lock is in use.

⚠ ATTENTION

Regard the safety instructions and the possible restrictions.

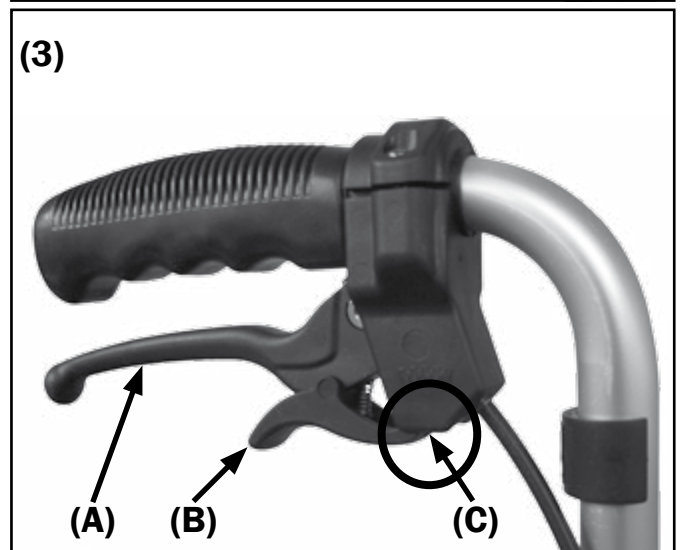
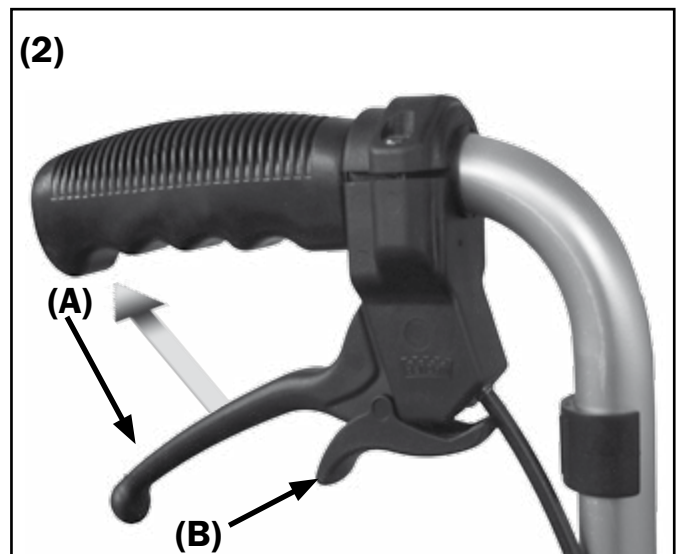
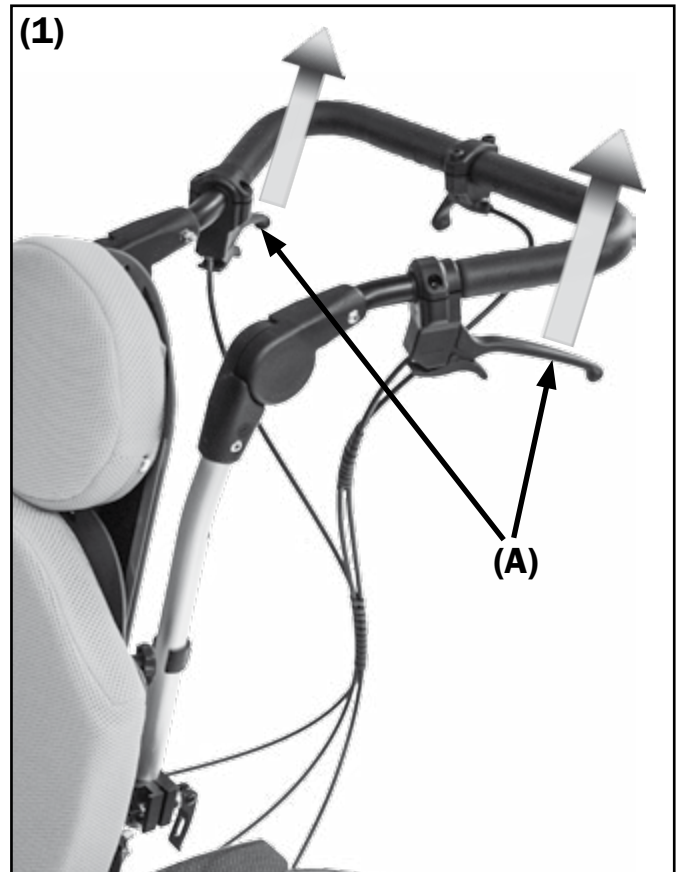

3.7 ANTI-TIPPER

(1+2) To activate:

- Push the anti-tipper (A) down using the tread element (B),
- turn it 180° backward
- and release it, so it snaps into place.

To deactivate:

- Push the anti-tipper (A), with the help of the tube, a little further down.
- Turn the anti-tipper 180° forward in driving direction and
- release it, so it snaps into place.

⚠ ATTENTION

(3) If you, the wheelchair user, activate the anti-tipper by yourself, be sure that you do not lean your body too far out of the wheelchair so that you do not fall out of the wheelchair.

If physically possible, hold on to the opposite side of the wheelchair with your free hand.

If necessary, use a suitable object to push down the anti-tipper (rod, cane).

⚠ ATTENTION

Make sure that the extension is always firmly snapped into its final position because a loose anti-tipper cannot fulfil its function properly and may cause injuries to the assistant's ankle area.

⚠ ATTENTION

If possible, always activate both anti-tippers!

⚠ ATTENTION

Please read the respective chapters of the SAFETY INSTRUCTIONS.

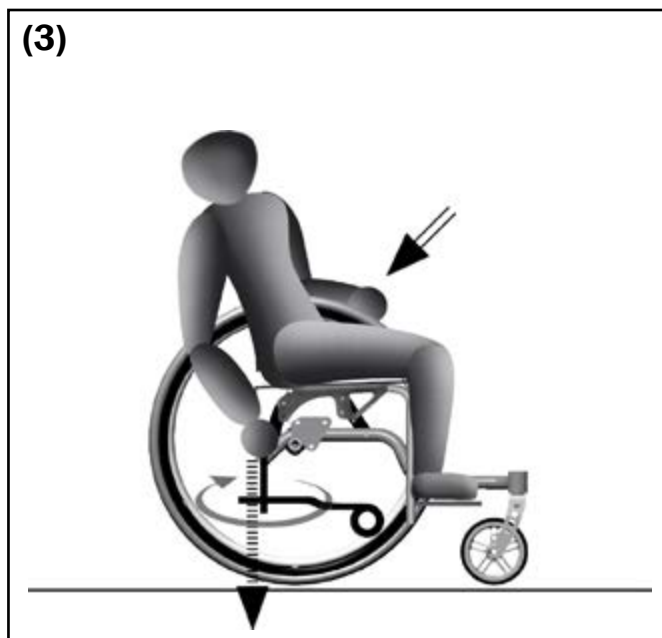
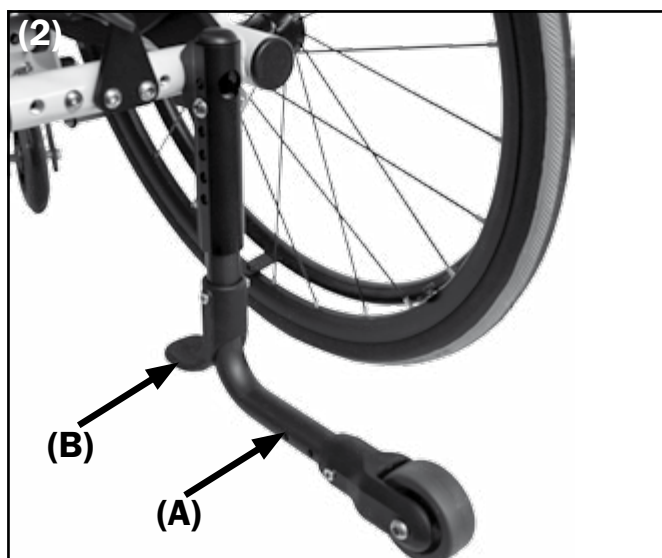
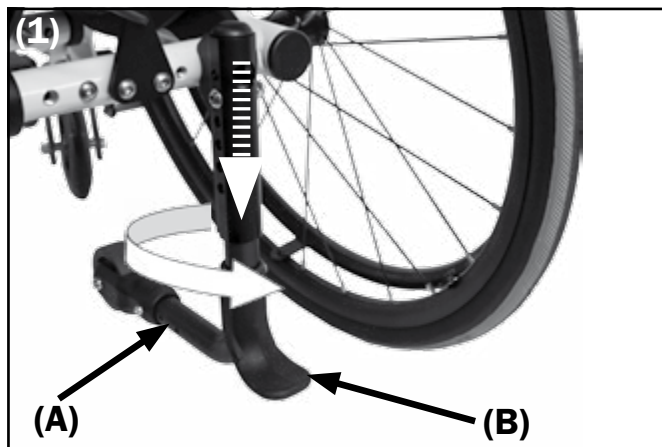

3.8 THORAX TRUSS PADS

(1) To open/close:

- Press the button **(A)** and
- at the same time, fold the truss pad arm **(B)** backward or forward.
- It snaps into place when you release the button **(A)**.

(1) To adjust the arm parts **(B) :**

- Close the truss pad.
- Loosen the screws **(C)** of the arm parts **(B)**
- and place them in the desired position.
- Retighten the screws **(C)**.

(1) To set the cushions **(D):**

- Loosen the screws **(E)** of the cushions **(D)**
- and place the cushions **(D)** in the desired position.
- Loosen the four screws **(F)** and
- turn the cushion **(D)** on the joint ball **(G)** to the wanted tilt.
- Retighten the screws **(F)**.

(2) To set the stop on the tuss pad holder:

- Close the truss pad and
- turn (from the outside) the set screw **(A)** open or closed as need so that the arm **(B)** is in the holder **(C)** without play, but the truss pad can still be opened and closed without a problem.

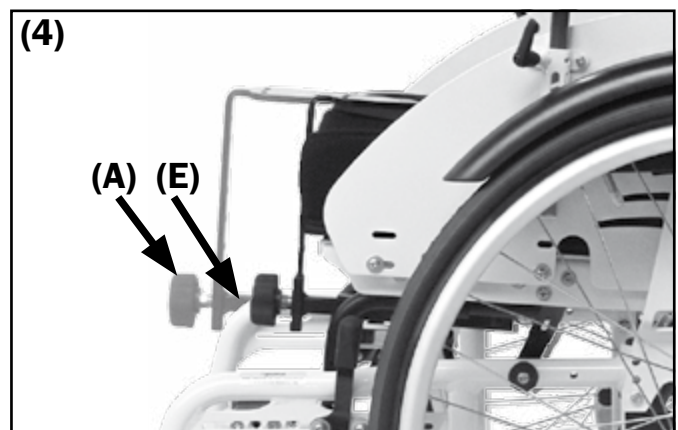
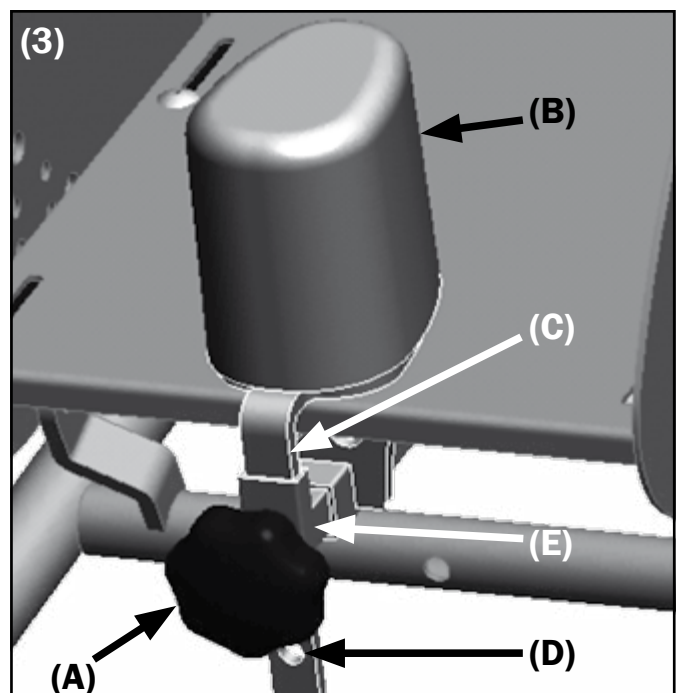
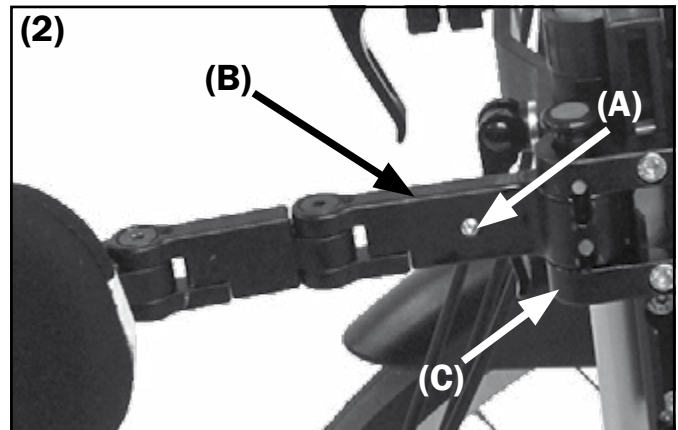
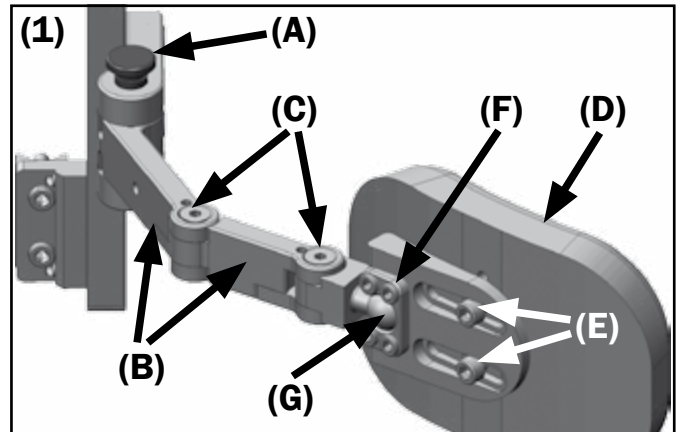

3.9 ABDUCTION WEDGE

The abduction wedge is mounted under the seat plate. The height can be adjusted in 1,5 cm intervals, the distance is infinitely variable.

⚠ ATTENTION

Before getting in and out the abduction wedge must be removed.

(3) To adjust the height:

- Remove the star knob screw **(A)**,
- move the cushion **(B)** with the holder **(C)** along the row of holes **(D)** to the desired height.
- Replace and retighten the star knob screw **(A)**.

(4) To adjust the distance:

- Loosen the star knob screw **(A)**,
- place the holder **(E)** to the desired distance
- retighten the star knob screw **(A)**.

3.10 HEAD RESTS

(1) Adjusting the height:

- Open the clamp lever (or the star screw) (A) and move the holder (B) to the desired position.
- close the clamp lever (or star screw) (A).

Adjusting the distance:

- Open the clamp lever (C),
- place the head rest cushion (D) with the holder (E) in the desired position and
- close the clamp lever (C).

Adjusting the cushion:

- The head rest cushion (D) can be adjusted in every desired angle with the ball joint (F).
- If necessary, in order to adjust the cushion (D) you may need to loosen or tighten the three screws on the ball joint (F).

⚠ ATTENTION

FOR THE TRANSPORT OF DISABLED PERSONS WE RECOMMEND A HEAD REST WHICH IS FIRMLY ATTACHED INSIDE THE VEHICLE.

⚠ ATTENTION

THE RESTRICTIONS AND REQUIREMENTS LISTED IN OUR CRASH-TEST BROCHURE REGARDING THE USE AS A HEAD REST IN A VEHICLE IS ABSOLUTELY BINDING!

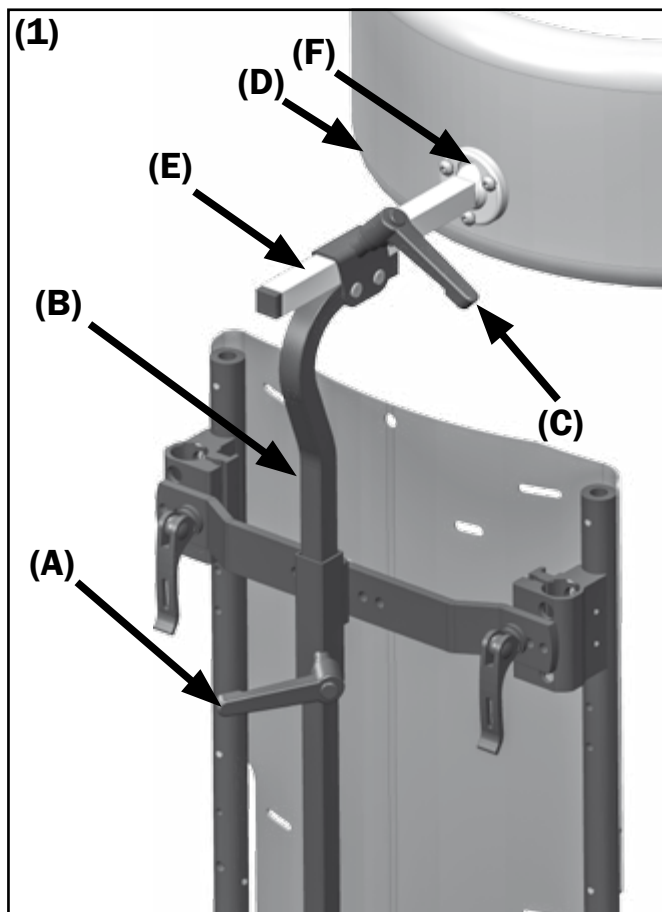

3.11 THERAPY TABLE

Please proceed accordingly with both connections:

- 1.) pluggable under both arm cushions,
- 2.) pluggable and able to fold down to the side under one arm cushion.

(2) In order to get in or out you must remove the therapy table or fold it to the side.

(3) Putting on/removing

- Loosen the star knob screw/s (A),
- place the tube/s (B) in the holder/s (C) and
- retighten the star knob screw/s (B).

(3) Setting the height

- When the therapy table is mounted on, loosen the clamp lever/s (D),
- place the therapy table to the desired height and
- retighten the clamp lever (D).

(3) Setting the depth

- When the therapy table is mounted on, loosen the star knob screw/s (A),
- place the therapy table to the desired distance and
- retighten the star knob screw/s (A).

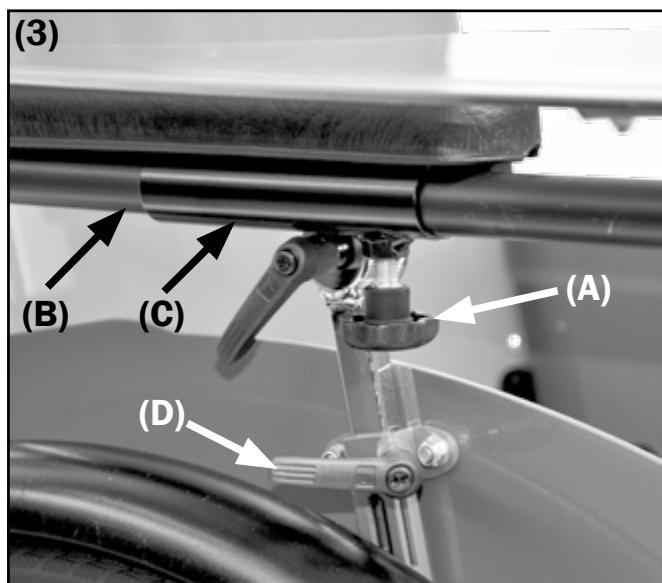
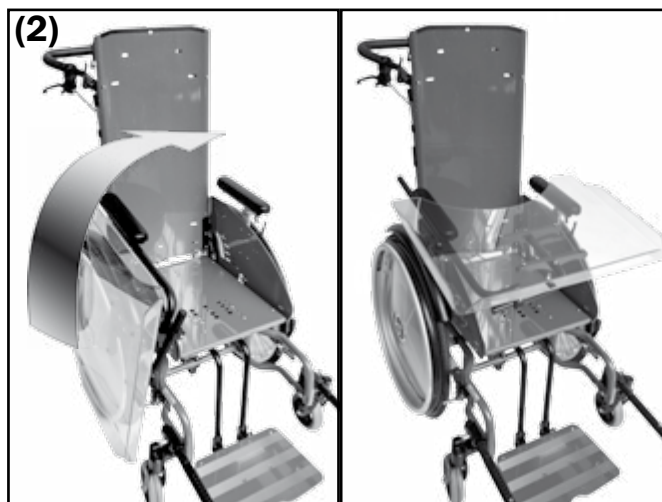

3.20 ARM CUSHION

(1) To adjust the height:

- Loosen the clamp lever **(A)**,
- guide the arm cushion **(B)** in the holder **(C)** to the desired position and
- retighten the clamp lever **(A)**.

(2) To adjust the angle:

- Loosen the clamp lever **(A)**,
- turn the arm cushion **(B)** in the rotary joint **(C)** to the desired angle and
- retighten the clamp lever **(A)**.

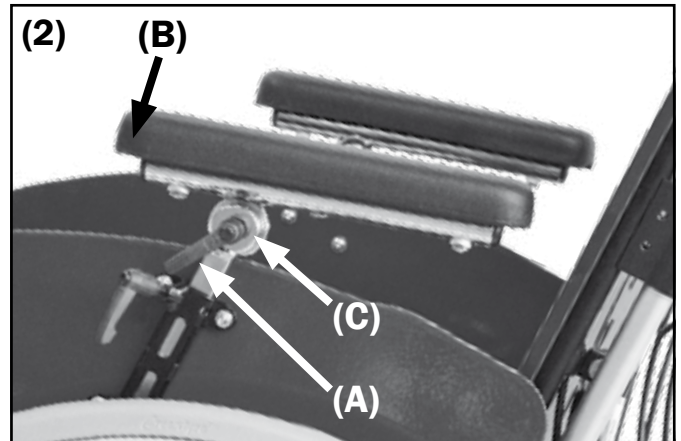
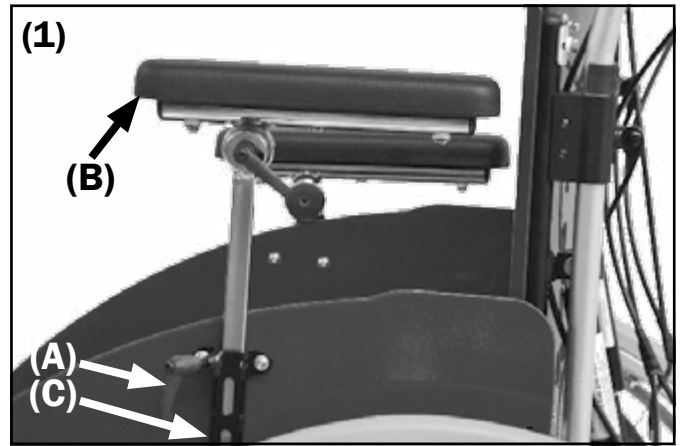

3.20 TIPPING LEVER

⚠ ATTENTION DANGER OF FLIPPING OVER

This maneuver should only be done by experienced and strong accompanying people.

To drive over an edge/threshold:

- **(3)** Deactivate the anti-tipper **(A)** and
- grab the wheelchair tightly on the push handles (push bail, handles or rod).
- With the tip of a foot push on the tipping lever **(B)** and tip the wheelchair slowly towards you.
- Drive the tilted wheelchair with the driving wheels to the edge **(C)** and
- push it on the driving wheels over the obstacle.
- Place the wheelchair in a horizontal position after the driving wheels are over the edge.

To drove off an edge/threshold:

- **(4)** Please proceed as described above.
- Drive the tilted wheelchair with the big driving wheels over the edge **(C)**.
- Place the wheelchair in a horizontal position after the driving wheels are over the edge.

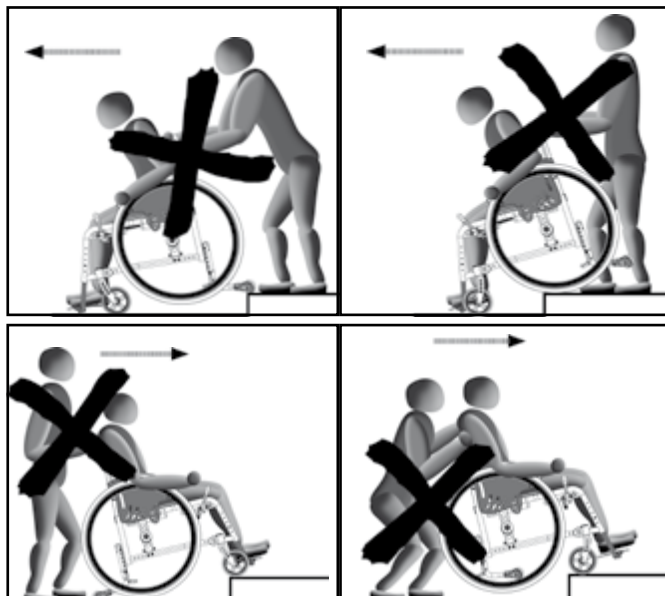
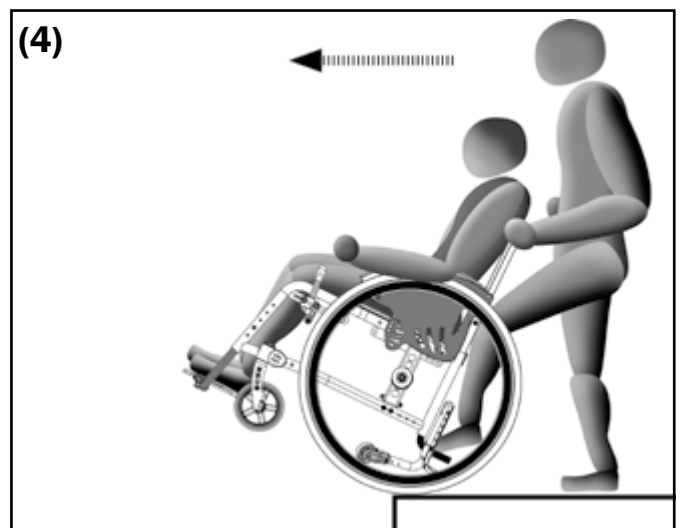
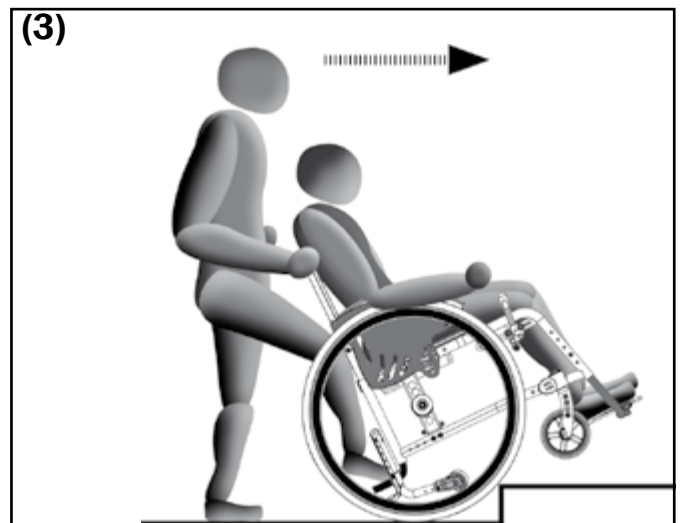

3.21 CANE HOLDER

⚠ ATTENTION

Fixate your cane with the appropriate Velcro band on the back of the wheelchair so that it does not accidentally get between the spokes.

3.4 ONE-HAND STEERING

To set the position of the steering lever:

- (1+2) push the safety clamp (A) up,
- (3) remove the steering lever (B) by pulling it up,
- (4) choose the desired position along the notch (C),
- press the steering lever (B) back down and secure it with the safety clamp (A) as in (1).

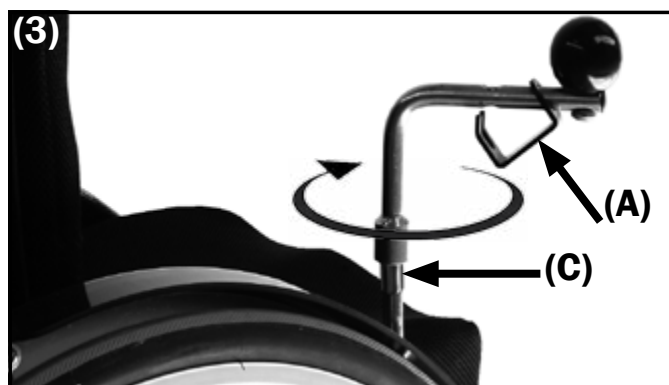

To activate the one-hand steering (OHS):

- turn the casters so they are facing forward (the OHS can only be activated or deactivated this way),
- (5) unlock the snapping mechanism (A) (pull latch (B) out and turn it 90°),
- (6) push the whole mechanism (A) down until it snaps into place
- and lock the mechanism again.

To deactivate the one-hand steering proceed accordingly.

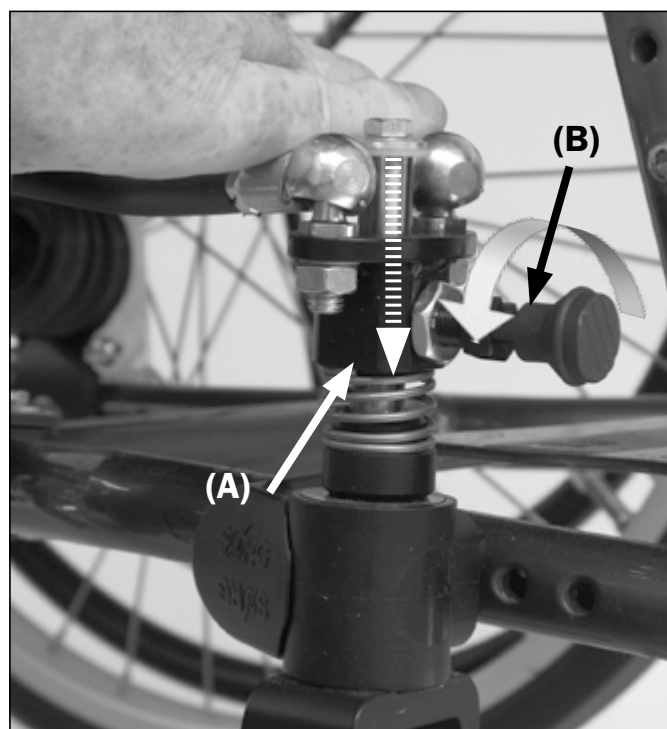
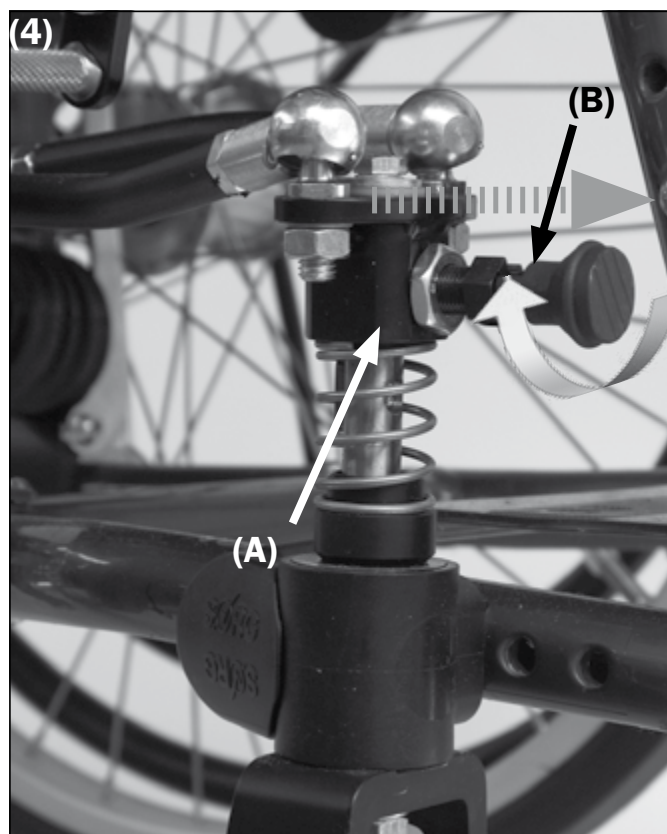

4. Repairs and maintenance

4.1 REPAIRS

ATTENTION

Do not conduct any reparations and/or maintenance work yourself. Contact your medical supply store. There, the staff is familiar with this work, has all necessary tools and are trained rehab technicians.

If you have any questions or need help, our qualified rehab consultants are happy to assist you or turn to your specialized retailer, who is trained according to our regulations and who is capable of resuming consultations, service as well as reparations.

4.2 SPARE PARTS

ATTENTION

Safety relevant parts or assemblies can only be built on or changed by a qualified medical supply store because of the safety hazards.

ATTENTION

Only original spare parts can be used! They are available at your medical supply store.

▶▶ INDICATION

Disruption can occur from assemblies from external companies which can lead to a safety hazard. Spare parts with the respective item number and drawings are available at your specialized store and can be downloaded under www.sorgrollstuhltechnik.de or can be requested directly from us.

For a correct delivery of spare parts the appropriate serial number of the wheelchair is to be stated! You will find these on the type label on the wheelchair's frame.

▶▶ INDICATION

Every change or modification done on the wheelchair by your medical store is to be enclosed in this user manual with the corresponding information such as assembling indications and/or operation instructions and the date of the alteration is to be documented in the service record.

4.3 DISPOSAL

▶▶ INDICATION

The wheelchair can only be disposed of after consultation and approval from your benefactor.

As a general rule, the disposal of the wheelchair must conform to the respective national legal regulations. You may seek information about local disposal organizations from your city or municipal administration.

Our packaging materials are 100% recyclable. Metal parts may be put to scrap metal recycling or sent to our factory. Plastic and textile parts may be recycled as well.

4.4 TIRE CHANGE

With a little bit of technical skill and suitable tools, you can fix a flat tire yourself. It is advisable to always carry a repair kit and an air pump for emergencies. Suitable air pumps can be purchased at your specialty store. An alternative would be a puncture repair spray which fills your tire with setting foam (available at the specialty store).

Dismounting

In case of a flat tire, remove the tire carefully from the rim with suitable mounting tools. Make sure not to damage the rim or the tube in the process.

Repair

Repair the tube according to the indications given on the reparation set, or replace it with a new one. Examine the rim and the interior of the tire for foreign objects which may have caused the flat tire. Only use rim bands which are in perfect condition to protect the tube from damage caused by spoke ends.

Mounting

Push the rim band over the valve and place the valve into the rim. Unscrew the valve screw nut. Now you can draw up the rim band effortlessly. Make sure that all spoke ends are covered.

Now push the lower tire part over the bead of the rim. Inflate the tire until round. Insert the weakly inflated tube into the tire cover. Check the tube for smooth fit. Then you can easily mount the upper part of the tire behind the bead of the rim with both hands. Start with the part of the valve which is faced away.

Inflation

Check if the tube is perfectly clamped between tire and cover.

Check the valve fitting.

First inflate the tire with just enough air so you can still push in with your thumb. Check the fit of the tire on the rim. If the tire cover is not centered on the rim, deflate the tire a bit and readjust it.

Then inflate the tire to its maximum operating pressure (see tire cover) and close the valve with the protection cap.

4.5 MAINTENANCE**4.5.1 Cleaning and Care****►► INDICATION**

Never treat the wheelchair with a high pressure cleaner! Please use silicon free, water based cleaning and care supplies.

The indications on application given by the manufacturer are to be followed. Do not use any aggressive cleaning supplies such as dissolvers or hard brushes etc.

COATING

To tend the finish, we recommend using customary branded finish care products. Should the coating still be damaged through scrapes, hits etc. you may correct those spots with a touch up applicator available in the specialty store (apart from metallic and dormant colors).

PLASTIC PARTS

The clothing protection and similar parts consist of high quality plastic. Only clean these parts with warm water and neutral cleaning agents or soft soap.

PLEASE NOTE:

When using customary plastic cleaners, the indications on application given by the manufacturer are to be followed.

CUSHIONS AND COVERS

The covers of the molded firm seat and back parts may be removed with the zippers. We recommend washing them regularly with a mild detergent and low temperature in the washing machine.

PLEASE NOTE:

Please clean other cushions and covers (e.g. from seat shells) with warm water and hand soap. Many stains can be removed with a sponge or a soft brush.

In case of doubt, please consult the medical supply

store, which built your seat shell, for advice on cleaning the cover.

FRAME

The frame and wheels must be cleaned regularly with a damp cloth and mild cleaning agent. Please dry well after.

CASTERS

Please remove rough dirt regularly from the casters, clean them with a damp cloth and mild cleaning agent and dry well. Please grease the wheel bearings and similar parts with customary grease.

PLEASE NOTE:

Please check the frame for corrosion damages as well as other damages on a regular basis. Oiling all versatile parts lightly and regularly obviates such damages and assures long use of your wheelchair.

4.5.2 Disinfection

To disinfect, water based agents should be used such as: Terralin, Quartamon, Med or Sagrotan.

The indications on application given by the manufacturer are to be minded and followed strictly.

 INFORMATION

Before you disinfect the wheelchair be sure to clean all cushions and handles in the given manner.

 INFORMATION

Do not use aggressive cleaning agents or solvents or hard brushes.

4.5.3 Reinstatement**►► INDICATION**

Before each reinstatement the wheelchair has to go through a complete, thorough and qualified inspection and disinfection.

►► INDICATION

The necessary measures for reinstatement are to be followed through according to a validated hygiene schedule.

4.6 SERVICE/INSPECTION

4.6.1 Check list

A yearly inspection from a qualified medical store is inevitable for the safe use of the wheelchair and for a long lifespan. Furthermore, the inspections serve as proof for the suitability for use in the case of a possible reinstatement.

For safety reasons and to prevent accidents resulting from abrasion not recognized on time, a yearly inspection is designated under normal operating conditions.

►► INDICATION

This is to be done according to the service list and to be documented in the service record.

According to applicable law §33 subparagraph 1,4 BSG V (Service, Maintenance, Replacement Reserve) the inspection is part of the commitment of the benefactor and has to be acquired by him. For detailed coordination, we recommend you arrange agreements with your benefactor in the forefront of supplying medical aids.

The staff of the professional repair shop is familiar with the technique of the aid and can recognize building abrasion and if necessary they can conduct the needed reparations.

4.6.2 Check list yearly inspection

PREPARATORY WORK

If necessary, we recommend cleaning the wheelchair or individual parts of it prior to inspection.

VISUAL INSPECTION

Check frame, mounting parts and accessories for damage, defects in paint work and corrosion.

GENERAL INSPECTION

- Check all fixing screws for firm fit and retighten them if necessary.
- Check fixation of all mounted parts and readjust if necessary.
- Check fixation of all plastic parts, handles, mounted parts spoke guard covers etc. and readjust if necessary.
- Check brake lever device and extension for deflection and readjust if necessary.
- Check all spring loaded devices (quick release axle, stand spring on push handle etc.) for proper functioning and replace if necessary.

CARRIAGE

Check fixation of caster and driving wheels.

- Check functionality of the quick release axles.
- Check tires, air pressure and valve, replace if needed.
- Check caster bearing, caster fork and caster mounting bracket for condition, proper functioning and running characteristics.
- Check the firm fitting of the anti-tipper and its functionality.

BRAKES

- Make sure the brakes function properly
- Make sure the Bowden cables function properly and replace if necessary.
- Make sure the brake lever extension functions properly.

OILING AND GREASING

Clean and grease all pivot points of control levers and versatile parts as well as all bearings.

FINAL INSPECTION

- General functional check-up of all mechanical adjusting devices.
- Additional braking, steering and driving tests uphill and downhill.

4.6.3 Service List

The following service list is based on our long-term experience and is a mandatory guideline with which you can keep your wheelchair – possibly for a long time – in a safe to use condition. However, it does not give information about the extent of service or repair needed and observed on the wheelchair.

ATTENTION

Please keep in mind, the even regular maintenance is not a guarantee for a safe use and road safety. If necessary, individual repairs and/or adjustment work is to be done immediately in order to ensure you are not in great danger.





Considering possible reuse, the filled out service plan is an informative document about the mobilization of the wheelchair for the benefactor.

ATTENTION

As a participant in public traffic, the wheelchair driver is responsible for maintaining the wheelchairs functional state and safe operating condition.

ATTENTION

Insufficient or neglected care and maintenance of the wheelchair pose a significant safety risk and automatically lead to limitations of product liability.

WHEN	WHAT	COMMENT
Before each use	<p>Check wheels/quick release axle for firm fit. You must not be able to pull the wheel out of the quick release axle. The locking button must protrude the hub visually on the inside of the chair.</p> <p>Check air pressure according to the manufacturer indication on the tire.</p> <p> ATTENTION Check the brakes regularly for proper function!</p>	<p> ATTENTION Too low air pressure and /or dirty tires as well as adverse weather circumstances can reduce the brake efficiency drastically and put you in danger. Fix all flaws yourself immediately or with an experienced carer.</p> <p>If the brake does not work correctly (worn off profile or braking bolt, loose brake lever etc.), contact a medical supply store immediately for qualified maintenance work.</p> <p> ATTENTION The wheelchair (with full capacity) has to stand safely with pulled brake on a ramp with a 7° (=12%) decline.</p>
Preferably before each use	<p>Check frame and back tubes for possible damages.</p>	<p>Please check:</p> <ul style="list-style-type: none"> • secure fit of the quick release axle, wheel adapter • angle adjustment elements (eccentric clamp or star knob screws) for proper function and completeness • fixation of footrest • fixation of seat plate and back as well as seat shell • fixation camber • fixation anti-tipper • proper function (clamping force) of all eccentric clamps • Velcro-fleece connection (seat and back belts) for proper function <p> ATTENTION If the welded seams are deformed and/or have fissures, contact a medical supply store immediately for qualified maintenance.</p>
Every 4 weeks	<p>Retighten all screw joints</p> <p>check tire profile</p> <p>Remove lint/dirt from casters</p>	<p>From daily use and the permanent vibrations screws can loosen. Therefore, we strongly recommend retightening ALL screw joints once a month.</p>
Every 2-3 months (depending on driving performance)	<p>Clean and grease all versatile parts.</p> <p>Retighten spokes.</p>	<p>All moving parts such as brakes, brake levers, quick release axles etc. Clean all parts thoroughly and remove old oil residue before greasing. After, Apply some drops of oil and wipe away excess oil.</p> <p>If possible, have this done by your medical supply store!!!</p>
Every 6 months (depending on driving performance, earlier)	<p>Check frame and back tubes for cracks, corrosion and damages.</p> <p>Maintain locking brake,</p>	<p>Have this done by your medical supply store! Please remove seat and back unit as well as leg support and side guards/clothing guard for better exterior visual control.</p> <p>To be conducted by the medical supply store! Inspect brakes for symptoms of fatigues or abrasions.</p>

4.7 TECHNICAL DATA

4.7.1 Measurements and dimensions

Dimension tolerance $\pm 5^\circ$

Abbreviations:

FW = frame width
SD = seat depth
BH = back height
LLL = lower leg length

Data

Model: Tilty Vario
German Aid Index Number.: 18.99.02.1013
Type: 602
Type plate on frame tube

4.7.2 Meaning of labels

The meaning of the individual labels is explained in the texts at the respective place.

The type plate on the frame of Tilty Vario has the following meanings (see bottom):

4.7.3 Measurements Tilty Vario

Misprints and technical changes reserved.

Indication	Measurements	Comment	
seat width (SW)	2-cm-intervals 28 to 44 cm	+4 cm growable	
seat depth (SD)	2-cm-intervals 30 to 44 cm	opt. +4 cm growable	
back height (BH)	5-cm-intervals 30 to 45 cm	+5 cm growable	
back angle:	80° to 120°	mechanical	
tilting	90° to 115°	gas pressure spring	
camber	3° or 7°		
seat height (SH) front with horizontal seat and horizontal frame	driving wheel 22" caster 4" caster 5" caster 6"	min. 38 max. 47 cm min. 38,5 max. 47,5 cm min. 41,5 max. 49 cm	WITHOUT cushion
	driving wheel 24" caster 4" caster 5" caster 6"	min. 38 max. 48 cm min. 39 max. 48 cm min. 41,5 max. 50 cm	WITHOUT cushion
absolute width of wheelchair	min.	SW + 320 mm,	dependent on camber
	max.	SW + 370 mm	
absolute length of wheelchair	with 22"	mm	dependent on wheel position
	with 24"	mm	
absolute height of wheelchair	min.	620 mm	without push handles!
	max.	990 mm	
incline	max. permitted	12,3% = 7°	
descent	max. permitted	12,3% = 7°	
stability	max. permitted	12,3% = 7°	
load capacity (max.)	max. 90 kg		
empty weight min. with SW 28, SD 30 cm, 22" wheels, 5" polyurethane casters	at 18,3 kg	Equipped with frame, rear wheels, handrims, casters, wheel lock, foot rest, side guards, skirtguard and anti tipper.	
wheels:	Standard and tread, light weight wheels	optional light weight drum brake wheels	
casters:	4", 5", 5,5", 6"	transparent mit LED, Vollgummi schwarz mit Alufelgen, PU grau mit Kunststofffelgen	
air pressure:	6-8 bar	Angaben auf den Reifen	
tires:	customary tires (1" bzw. 1 3/8") or puncture proof tires	optional Schwalbe Marathon Plus, pneumatic tires with puncture proof insert	
support point:	frame cross bar		
heaviest piece:	driving wheels	1,2-2,2 kg	

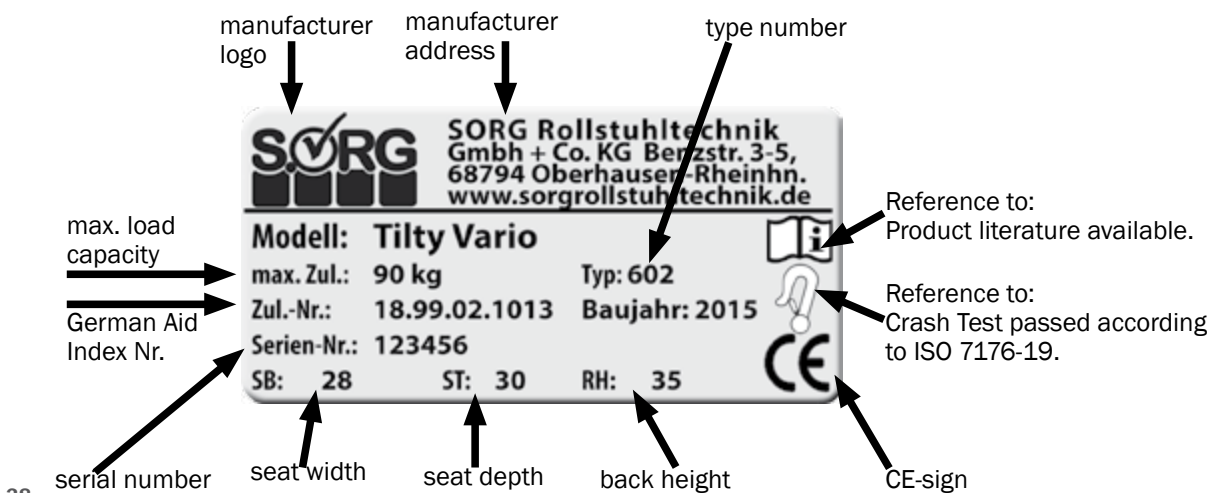

4.8 DOCUMENTATION YEARLY INSPECTION

Work done according to check list	Additional work carried out	Date, signature, stamp medical supply store,

4.9 RETAILER VERIFICATION

company stamp



SORG Rollstuhltechnik
GmbH + Co. KG
Benzstraße 3-5
D-68794 Oberhausen-Rheinhn.

Tel +49 7254-9279.0
Fax +49 7254-9279.10

info@sorgrollstuhltechnik.de
www.sorgrollstuhltechnik.de
Technical changes and misprints reserved.