

SÖRG
Rollstuhltechnik

User Manual

Mio



IMPRINT

SORG Rollstuhltechnik GmbH+Co.KG
Benzstraße 3-5
D-68794 Oberhausen-Rheinhausen
Germany

Tel. +49 7254-9279-0
Fax +49 7254-9279-10
E-mail info@sorgrollstuhltechnik.de
Web www.sorgrollstuhltechnik.de

REVISION STATUS

Revision from September 15, 2015

TECHNICAL STATUS

Technical changes and misprints reserved. The pictures in this user manual can – depending on the individual equipment – differ from the actual equipment components. However, a corresponding conduction is possible.



rehaKIND



We are a member of rehaKIND e.V.
International association
child and adolescent rehabilitation

COPYRIGHT

© by SORG Rollstuhltechnik GmbH + Co. KG Benzstraße 3-5, 68794 Oberhausen-Rheinhausen.
All texts and pictures in this user manual underlie the international copyright protection and are not allowed to be published without our consent – not even in excerpts!

CERTIFICATION

We are certified according to the Quality Management System ISO 90001:2008 under the certificate no. 12 100 20070 at TÜV SÜD.



IMPRINT	2	3.6 Side guard/skirt guard	22
REVISION STATUS	2	3.7 Push aids	23
TECHNICAL STATUS	2	3.7.1 Push bails /Push handles	23
rehaKIND	2	3.7.2 Angle adjustment push aids	24
COPYRIGHT	2	3.7.3 Tensioning force of eccentric clamp	24
CERTIFICATION	2	3.8 Leg supports	25
wheelchair overview	4	3.8.1 Standard leg support	25
		3.8.2 Leg support foldable	25
		3.8.3 Locking	25
1 Preamble	5	3.9 Brakes	26
1.1 General information	5	3.9.1 Drum brake as driving brake	26
1.2. Signs and symbols	5	3.9.2 Drum brake as wheel lock	26
1.3 Indication	5	3.9.3 Knee lever brake (wheel lock)	26
1.4 Counter indication	5	3.10 Anti-tipper	27
1.6 Application	6	3.11 Head rests	27
1.5 Specification Mio	6	3.12 Abduction wedge	28
1.7 Reception	7	3.13 Therapy table	28
1.8 Documentation	7	3.14 Thorax truss pads	28
1.9 Service and maintenance	7	3.15 Push aid for outside (Outdoor Front End)	29
1.10 Accessory and attachment drives	7		
2 Safety Instructions	8	4. Repairs and Maintenance	30
2.1 General indications	8	4.1. Repairs	30
2.2 Handling	8	4.2 Spare parts	30
2.2.1 Getting in and out	8	4.3 Disposal	30
2.2.2 Starting and slowing down	9	4.4 Tire Change	30
2.2.3 Danger of tipping and flipping over	9	4.5 Maintenance	31
2.2.4 Up and downhill	11	4.5.1 Cleaning and Care	31
2.3 Changing seats independently	12	4.5.2 Disinfection	31
2.4 Grabbing objects	13	4.5.3 Reinstatement	31
2.5 Overcoming obstacles	14	4.6 Service/Inspection	32
2.6 Wheel lock	16	4.6.1 Check list	32
2.7 Anti-tipper	16	4.6.2 Check list yearly inspection	32
2.8 Angle adjustable back and seat tilt	17	4.6.3 Service List	32
2.9 Casters	17	4.7 Technical Data	34
2.10. Loading and transporting	18	4.7.1 Measurements and dimensions	34
2.10.1 Transport in public transportation	18	4.7.2 Meaning of labels	34
2.10.2 Transport in other vehicles	18	4.7.3 Measurements Mio	34
2.11 Other risks	19	4.8 DOCUMENTATION YEARLY INSPECTION	35
3 Handling	20		
3.1 Wheels	20		
3.1.1 Quick release axle wheels	20		
3.1.2 Drum brake wheels	20		
3.1.3 Double hand rim	21		
3.2 Casters	21		
3.3 Special hand rims	22		
3.3.1 Knob hand rims	22		
3.3.2 Hand rim covers / Maxgrepp hand rims	22		
3.4 Seat	22		
3.5 Back	22		
3.5.1 Standard back	22		
3.5.2 Back extension submersible	22		

wheelchair overview

Overview Mio

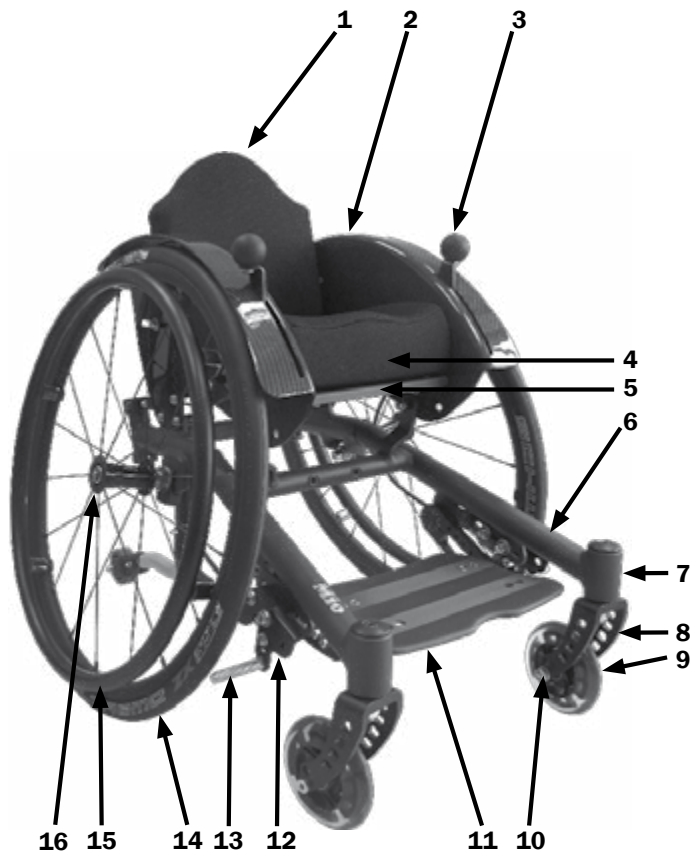

1. back cushion (for curved back plate model 3)
2. active side guard with built-in cable brake
3. brake lever (for cable brake)
4. anatomically formed seat
5. firm seat plate
6. *taurus frame* (with small abduction)
7. caster adapter
8. caster fork
9. caster
10. caster axle
11. foot plate
12. locking brake
13. brake pressing bolt
14. driving wheel
15. hand rim
16. quick release axle



1. height adjustable push bail
2. angle adjustment for push bail
3. firm curved back plate (model 3)
4. side guard
5. driving wheel
6. hand rim
7. anti-tipper
8. locking lever (eccentric clamp) for push bail
9. loop to mount hand rims (wide/tight)

1 Preamble

1.1 GENERAL INFORMATION

The wheelchair has been built, adjusted and given to you operable according to your individual instructions. A qualified Technician will make any changes necessary, should modification be needed during use.

As any other aid, a wheelchair is a technical device that can hold risks if not properly used. This brochure is to help you familiarize yourself with the wheelchair and its functions.

ATTENTION

Read the following instructions and manuals carefully.

- User manual
- Info-brochure Crash Test ISO 7176-19

ATTENTION

If the user of the wheelchair is a child or a person with limited competence, the parents or authorized supervisor have to make sure that they have fully understood the handling of the wheelchair before it is first used.

If you have any questions your medical supply store or our competent team is glad to assist you (+49 07254/92790).

This user manual is directed to both you and your rehab technician. It contains instructions on the correct adjustments of Jump to your physical situation.

1.2. SIGNS AND SYMBOLS

ATTENTION

This is how **individual-related** safety aspects of **utmost importance** are indicated.

INDICATION

This is how possible **indications** of **utmost importance** are labelled.

INFORMATION

This is how **INFORMATION** on mounting and adjustment work is labelled.

READ

This refers to other chapters within the brochure or to additional material.

BOLD PRINT

Text in bold print highlights important passages or remarks.

1.3 INDICATION

Mio is a small, light, active wheelchair which can grow for children 12 months of age. Mio has two frame variations (retro and Taurus) with two differently strong v-shaped abductions and a fixed camber of 9°. The seat-back-unit can be precisely set according to the shoulder-rear wheel-position for an ideal gripping point. Mio is also suitable as a base for a seat shell build.

It is indicated by/to:

- brittle bone disease (BBD)
- all forms of neuromuscular sicknesses
- all forms of muscular atrophy
- all forms of muscular dystrophy
- muscular torso-hypotension
- infantile Cerebral Palsy
- Spina bifida
- spinal amyotrophy
- progressive muscular dystrophy
- restricted or missing head control
- muscle changes
- skeletal deformities
- build and strengthen the whole bone structure
- build and activate the whole muscle tone
- reactivate after a severe concussion
- stabilize scoliosis
- regulate dyskinesia

With the Mio, the following therapeutic goals can be supported:

- vestibular stimulation
- transfer of the perception of mobility with, at the same time, an upright stance
- preservation, developing and/or strengthening of the entire muscle tonicity
- preservation, developing and/or strengthening of (auto-)mobility
- stabilizing the torso and putting it into an upright position
- skeletal stabilization, strengthening of the spine
- stimulation and stabilization of the metabolism and circulation
- participation in social life (inclusion)

1.4 COUNTER INDICATION

Mio is counter indicated by:

- tonicity deregulation
- perception disorders
- high disturbances of equilibrium
- limb loss on both arms
- joint contractures/joint damages on both arms
- unable to sit
- not enough eyesight

ATTENTION

Under the following circumstances and/or symptoms, the active and/or passive use of the Mio must be thoroughly discussed with the doctor or therapist in charge of treatment.

- **Users without intact skin (especially in the areas of the buttocks, back, thigh, hands etc.) may experience dermatological complications (pressure marks, irritations, open traumata)**
- **with severe tonicity deregulation**
- **with extreme restricted perception, the active participation on the street is NOT possible without a accompanying person.**

▶▶ INDICATION

We are NOT liable for health problems and/or other damages on persons or objects that occurred from using the Mio, despite the above described conditions.

1.5 SPECIFICATION MIO

Mio is a light and versatile active wheelchair for indoors and outdoors (apartment, school, work, leisure time, travels). Its aluminum frame displays excellent driving qualities. The frame is available in two different V-shaped abductions and two different shapes (**Taurus/retro**). Through its frame, Mio gains high torsion rigidity.

For a long term, effective therapeutic use the back height, seat depth and seat width were designed to grow. It ideally adjusts to the physiognomic circumstances.

For the seat-back-area Mio is equipped with various possibilities in order to meet the many different therapeutic demands:

- firm seat plate with firm curved back plate,
- anatomical seat and back units
- and all kinds of seat shells (type 1-3).

Mio can be used for children and adolescents starting at a seat width of 18cm and up to a maximum load of 50 kg.

- Frame size 1 (20" wheel)
- Frame size 2 (22" wheel)
- Frame size 3 (24" wheel)
- *(frame size "0" with 18" wheel only after consultation)*

The allowed max. load of 50 kg cannot be exceeded.

1.6 APPLICATION

ATTENTION

The wheelchair serves solely to actively or passively transport the person to whom the wheelchair has been adjusted for by a qualified specialized trade.

It can be used on firm ground without any restrictions indoors and outdoors. With suitable equipment (e.g. outdoor front end) the wheelchair can also be used on surfaces such as sand, cobblestones, gravel etc.

ATTENTION

The allowed load capacity (including seat shell) is not to be exceeded.

ATTENTION

The wheelchair cannot be used in extremely wet surroundings (shower, sauna etc.) or salt water nor can it have excessive contact with moisture.

ATTENTION

The wheelchair must not be used as means of transportation for goods, objects and the like.

INFORMATION

Regular maintenance and care (after chapter 4) is necessary for the guaranteed service life of the wheelchair.

1.7 RECEPTION

PLEASE NOTE DELIVERY

Each wheelchair is mounted, tested for functionality and correctness in our works and packaged into special cardboard boxes by our shipping experts.

FORWARDING COMPANY

For liability reasons we have to ask you to check the wheelchair immediately after receiving it and in the presence of the deliverer (forwarding company) for possible damages that may have occurred during transportation.

TRANSPORTATION DAMAGES

In case of damage, please proceed as follows:

- write a short record of the damage and review of events, if possible include pictures clearly showing the damage,
- get the personal information of the bearer (driver's license etc.),
- inform us immediately.

» INDICATION

Do not sign the notice of receipt from the forwarding company before thoroughly checking the wheelchair for defects.

» INDICATION

According to the valid law, damages reported late can neither be asserted to us nor to the forwarding company.

1.8 DOCUMENTATION

» INDICATION

Keep this user manual in a safe place. Have all work/repairs done on your wheelchair documented by the medical supply store in the maintenance plan. If applicable, hand it back to your benefactor along with the wheelchair.

» INDICATION

In the event of the wheelchair being reused, the service book is an important source of information for you benefactor. It provides evidence of regular inspections which might be relevant in the event of warranty claim.

ATTENTION

For safety reasons have all repairs done and documented solely by a qualified specialized trade.

1.9 SERVICE AND MAINTENANCE

READ

According to § 33 subparagraph 1, clause 4, [German] SGB V, the responsibility of maintenance, repairs and replacement lies with the benefactor. After agreement with your benefactor, be sure to have all safety relevant inspections, maintenance work and if necessary repairs conducted in order to make the wheelchair functional.

ATTENTION

Be careful with all moveable parts since there is a RISK of crushing fingers and other body parts.

ATTENTION

The regular inspection of all safety relevant parts on the wheelchair by a qualified rehab workshop is the only way to prevent damages and maintain our liability.

ATTENTION

Only original parts are to be used for all service and maintenance work.

INFORMATION

Proceed according to the maintenance plan in chapter 4 of this user manual.

1.10 ACCESSORY AND ATTACHMENT DRIVES

ATTENTION

The addition of these accessory and attachment drives is done by either the manufacturer or the sanitary house and solely in their responsibility

INFORMATION

Ask the manufacturer for the respective requirements.

2 Safety Instructions

2.1 GENERAL INDICATIONS

ATTENTION

The risk of injuries is on all rotatable and turnable parts. This also goes for adjustment and repair work.

ATTENTION

The wheelchair can only be used according to its specifications. Any other use or misuse can contain serious risks for you and your surroundings. Also the guarantee or product liability can be terminated in case of misuse.

Slowly familiarize yourself with the wheelchair at the first use and after adjustment work has been done. First practice on level grounds with the help of an experienced person. Only then are you allowed to try uphill and downhill with the help of an experienced person.

From putting on and taking off the accessories, the measurements of the wheelchair, its weight, the handling and tilting changes.

ATTENTION

A strong seat inclination plus a very active rear wheel position plus unfavorable posture can cause tipping over even on a flat surface.

ATTENTION

All mounting alterations on your wheelchair must be coordinated and made by the manufacturer or your rehab technician.

ATTENTION

Do not make any adjustments, repairs and/or do maintenance work yourself. Contact your qualified medical supply store.

READ

Consider the indications for maintenance and inspection on your wheelchair at the end of the operating instructions.

2.2 HANDLING

2.2.1 Getting in and out

ATTENTION

(1) Getting in and out can only occur on a flat surface and with ACTIVATED WHEEL LOCK. Activate the tilt safety for each transfer and always turn the caster forward in order to enhance the stability.

Let someone help you getting in and out if possible/necessary. Let the helping person know of possible hazards such as tripping, edges and your degree of disability.

ATTENTION

(2) NEVER use the footrest/s to get in and out. The wheelchair can tip forward. Please fold (when possible) the footrest/s to the side or to the back in order to get closer to the wheelchair.

INDICATION

(3) For some children it is asked for, therapeutically, that they get in and out on their own by using the footrest. In this case consider the following:

- turn casters forward,
- secure the wheelchair from rolling away,
- activate tilt safety,
- don't let the child get in and out unattended,
- be ready to give assistance.



2.2.2 Starting and slowing down

ATTENTION

Avoid jerky starts. The wheelchair could tip backwards. Thus, when possible, lean your upper body forward when starting. With children we always recommend to use the tilt safety whenever possible.

ATTENTION

While driving, braking occurs through controlled pressure applied to the hand rims from your palms/fingers. Please keep in mind that you require more strength in order to brake going downhill. When driving downhill make sure to drive slow enough that you are able to bring the wheelchair to a full stop at any time.

ATTENTION

Also keep in mind that the hand rims heat up from friction (especially hand rims with a cover).

ATTENTION

If necessary, use gloves with a leather inner surface as used by cycling, but NEVER wool gloves.

2.2.3 Danger of tipping and flipping over

ATTENTION

Generally the hazard of flipping and tipping occurs (also see pictures on the next page)

- (1) from all kinds of height differences of the ground surface,
- (2) from stairs (never manage alone),
- (3) from participation in public traffic under the influence of medication, drugs, alcohol, etc.,
- (4) when driving uphill and/or the emphasis of different objects on the back of the wheelchair,
- (5) when leaning out of the wheelchair,
- (6) from longitudinal grooves such as streetcar rails (hazard of getting stuck). Always cross at a 90° angle.

(1)



(2)

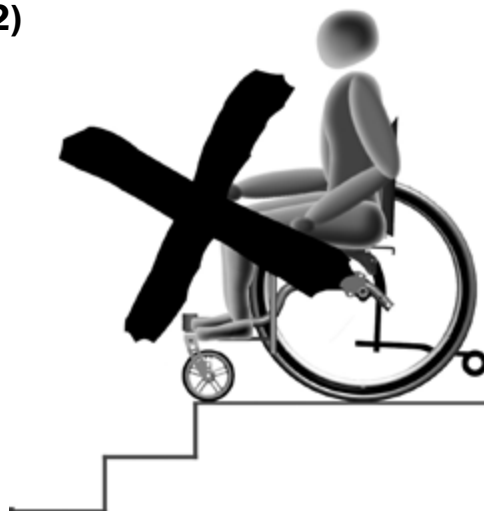

(3)



(4)



(5)



(6)

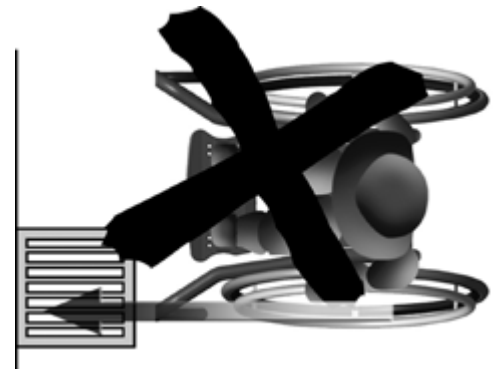
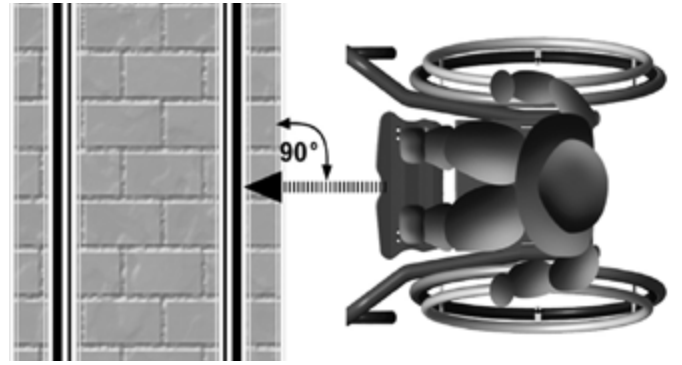
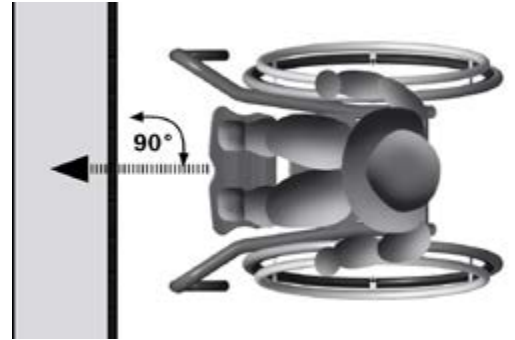
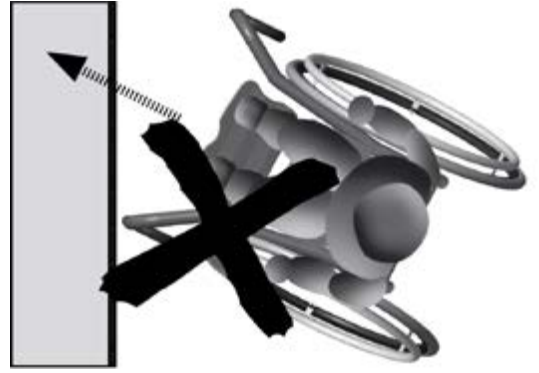

2.2.4 Up and downhill

⚠ ATTENTION

Keep in mind the higher strain in order to drive or brake going up or downhill (see 2.2.1).

⚠ ATTENTION

(1) If possible, tilt your upper body, when driving up or downhill, in the direction of the hill.

⚠ ATTENTION

Only go up ramps or hills with an incline or descent greater than 6% with assistance.

⚠ ATTENTION

NEVER go on ramps or hills WITHOUT the anti-tipper activated.

⚠ ATTENTION

(2) NEVER drive on inclines, descents or curbs sideways to the road, you may tip over.

(1)

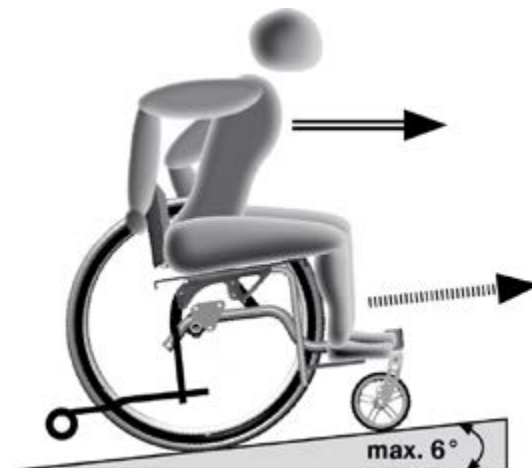
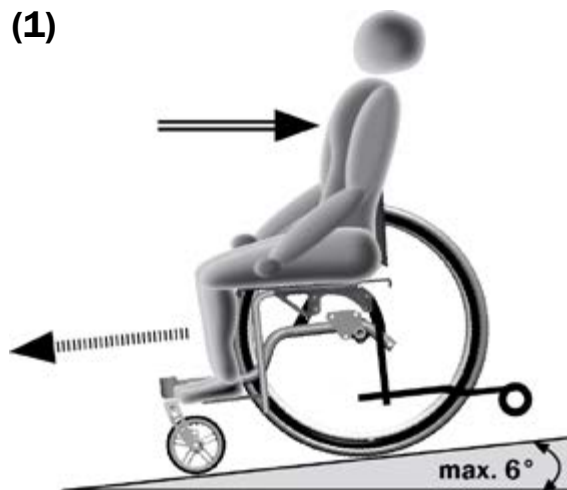

(2)



2.3 CHANGING SEATS INDEPENDENTLY

⚠ ATTENTION

Changing seats independently is dangerous and requires experience. Practice this first with the help of a carer, before you change seats by yourself.

⚠ ATTENTION

The footrests are located in the leg area, whereby the danger of tripping can occur! Make sure that the footrest is NOT in the maneuver area! Otherwise, change the transfer side if possible. Fold the footrest/s, if possible, away or flip the leg support/s out.

(1) In order to transfer independently drive as close as possible (forwards or in a 45° angle) to the other seating area and assure yourself of the firm fixation. If possible, flip the side part back. Lock the wheel lock and hold on to the new, nonslip seat

(2) It is an advantage to have a nonslip board or a similar device. Make sure that the nonslip board is securely on the surface and can't slip around itself and proceed as already described.

(1)



(2)



2.4 GRABBING OBJECTS

Carefully test the tilt behavior of the wheelchair to the side, front and back **with the help of an experienced and strong helper**.

⚠ ATTENTION

(1) Do not grab objects behind the wheelchair reaching over the back of the chair, DANGER OF FLIPPING OVER. Turn the wheelchair around and go towards the object from the front or the side.

⚠ ATTENTION

In order to grab objects from the side/in front of the wheelchair secure the wheelchair from rolling away! Do not lean too far out of the wheelchair.

▶ INDICATION

Generally, using a reacher is safer.

(2) If possible, when leaning out of the wheelchair sideways, hold on to something on the opposite side with your free hand and try not to shift too much weight.

(3) If you have to lean forward out of the wheelchair, **NEVER** strain the leg supports, **DANGER OF FLIPPING OVER!** First turn the casters forward for better positioning.

In addition, (if possible) put both feet on the ground, preferably as far from you as possible. Here you are generally on the safe side if you use a reacher. Your medical store will gladly advise you.

(2)



(3)



(1)

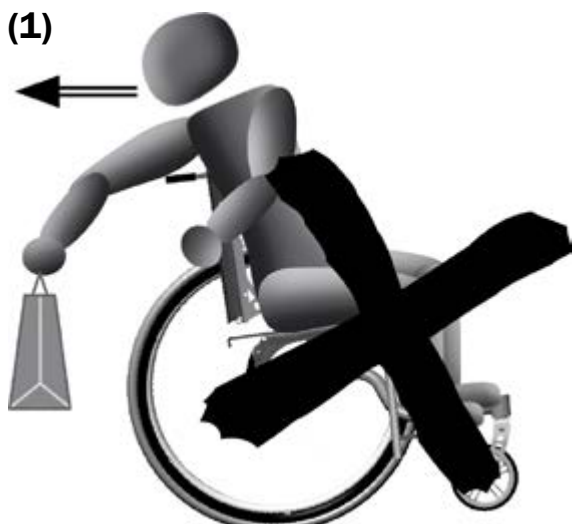

2.5 OVERCOMING OBSTACLES

⚠ ATTENTION

A WHEELCHAIR IS NOT FOR CARRYING. IT WAS NOT DESIGNED NOR TESTED OR BUILT FOR THIS:
For this reason avoid stairs whenever possible!
Instead to overcome height differences use ramps or elevators.

⚠ ATTENTION

(1) NEVER overcome stairs etc. with the wheelchair ALONE.

⚠ ATTENTION

(2) Only overcome stairs with the help of two experienced people. For this, the anti-tipper must be deactivated. Be sure that the wheelchair is only held by metal parts which are screwed securely to the frame.

⚠ ATTENTION

(3) NEVER PULL OR CARRY THE WHEELCHAIR OVER AN OBSTACLE BY THE REMOVEABLE SLIDING HANDLE OR THE PUSH HANDLE.

⚠ ATTENTION

The plastic caps on the push handle can loosen due to adverse conditions (heat, precipitation, heavy strain etc). Inform your carer of the dangers.

⚠ ATTENTION

The same goes for the removable leg support, foldable desk side guard and/or foot rests.

⚠ ATTENTION

Do not under any circumstances use escalators, not even with a carer. Shopping malls and public building with escalators always have elevators as well.

(1)



(2)



(3)

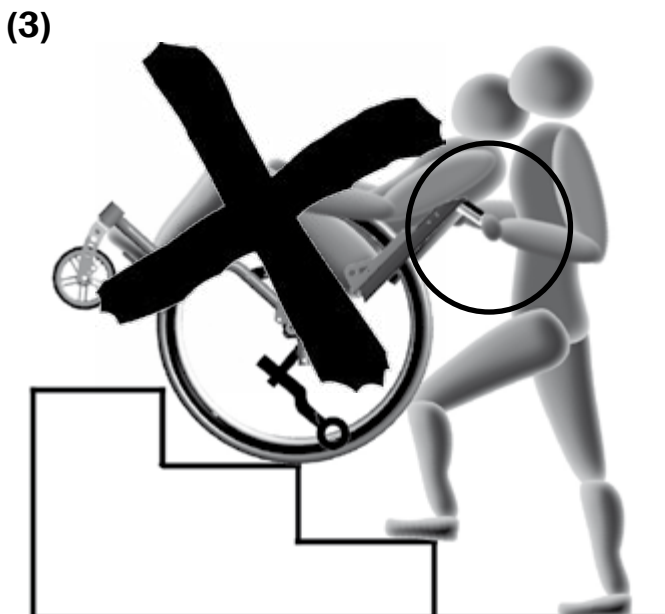

⚠ ATTENTION

Do not drive towards, for example, curbsides without braking, **DANGER OF TIPPING OVER!**

⚠ ATTENTION

(1) In order to overcome height differences or when using an elevator and lifting platforms, you generally have to deactivate the anti-tipper. You could become restricted in maneuverability.

(2) In order to overcome curbsides your carer should slightly tilt you backwards, lift both casters over the threshold and then, with the driving wheels, carefully push the wheelchair over the edge-**DO NOT LIFT**. The anti-tipper must be deactivated.

(3) When driving off of the curb please proceed correspondingly.

⚠ ATTENTION

For this, the casters must stay in the air until the rear wheels are over the threshold. **DO NOT** put the caster down first, **DANGER OF FLIPPING OVER.**

(4) Practiced drivers can overcome curbsides with the so called wobbling without someone's help. Slowly and with the help of a carer familiarize yourself with this technique.

⚠ ATTENTION

This maneuver requires a lot of practice and control over the wheelchair!

- **Drive** slowly in a 90° angle up to the spot you want to overcome and wobble the wheelchair slowly backwards so that the casters do not have contact to the ground.
- **Bring** the casters hanging in the air over the threshold/edge and drive the wheelchair up to the obstacle.
- **Drive** over the threshold/edge with your upper body leaning forward as far as possible and put the casters down on the ground after.

(1)



(2)



(3)

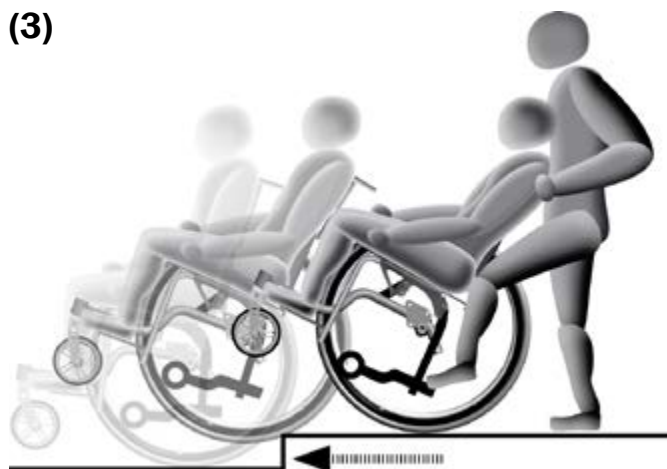

(4)



2.6 WHEEL LOCK

⚠ ATTENTION

The knee lever brake is a wheel lock and **NOT** designed to brake during the drive. While driving, (especially downhill) you could bring the wheelchair to a sudden full stop, whereby you could fall out of the wheelchair. A service brake, such as a drum brake, allows controls braking.

⚠ ATTENTION

Before each drive make sure to check

- the correct tire pressure (information is on the outer tire)
- and if necessary the brake pressing bolt.
- and if necessary the cable controls

⚠ ATTENTION

Cable controls are high maintenance! Especially the clamp screws and the Bowden cable need to be checked on a regular basis and retuned if necessary. These cable controls are used for:

- Drum brakes
- Cable brake (integrated in the side guard)
- One hand brake
- Accompany brake (only by older models).

⚠ ATTENTION

The reverse gear stop is effective on an incline of max. 12,3% (=7°) with a load (passenger incl. seat shell or similar) of up to 90kg.

⚠ ATTENTION

Regularly remove lint and dirt from the brake bolts.

⚠ ATTENTION

Keep in mind that dirt, wetness, ice, snow, mud etc. can impair the brake force of the wheel lock.

⚠ ATTENTION

Do not make repairs on the wheel lock yourself. Ask your rehab technician.

⚠ ATTENTION

After all changes on the rear wheels (position of the axle plate, tire changing) the functionality of the wheel lock must be checked and if necessary newly adjusted.

2.7 ANTI-TIPPER

⚠ ATTENTION

We recommend inexperienced and young users to use the anti-tipper whenever possible.

▶▶ INDICATION

Additionally, each one of our wheelchairs can be equipped with anti-tippers.

(1) In order to independently activate the anti-tipper you must secure the wheelchair from rolling away, slowly reach behind you without leaning too far out of the wheelchair, push the anti-tipper down and turn it 180° on its own axis until it snaps back into the guide slot. If possible hold with your other hand on to the rear wheel/hand rim on the opposite side:

⚠ ATTENTION

(2) When overcoming height differences or when using elevators or lifting platforms deactivate the anti-tipper. You could become restricted in maneuverability.



(2)



2.8 ANGLE ADJUSTABLE BACK AND SEAT TILT

⚠ ATTENTION

(1) With an angle adjustable back or seat tilt the anti-tipper is to be activated starting from a setting of 90°.

⚠ ATTENTION

For active use the back or seat tilt must be in an upright (90°) position.

Make sure that when adjusting the back angle or when tilting that the head has enough support from for example a head rest.

⚠ ATTENTION

NEVER activate the seat tilt or the angle adjustment while driving.

▶▶ INDICATION

(2) In the case of amputations or leg elevation and simultaneously “leaning back”, we recommend for improvement of the tilt stability a wheel base elongation, at least the use of an anti-kipper.

⚠ ATTENTION

A wheel base extension is strictly **NOT** a replacement for an anti-tipper!

2.9 CASTERS

⚠ ATTENTION

Casters which are not correctly adjusted or driving too fast, especially downhill, can cause the casters to dangerously flap back and forth.

▶▶ INDICATION

Clean the axes and the axle holder regularly, removing lint and dirt.

ℹ INFORMATION

After every change on the rear wheels the casters must be newly adjusted. Let this be done by an experienced rehab technician.

▶▶ INDICATION

(3) When transferring in and out of the wheelchair turn the casters forward for greater stability by slightly moving the wheelchair backwards.

(1)



(2)



(3)



2.10. LOADING AND TRANSPORTING

For the transport of your wheelchair in a car please consider the following points:

- If necessary flip the anti-tipper inwards.
- If necessary remove the push handle/s or handle bars.
- If possible remove the hollow molded back and fold the back down.
- If possible fold the wheelchair and close it securely with the folding fixture strap.
- Unlock the wheel lock and remove the driving wheels.
- Secure the wheelchair with tension belts in the vehicle.
- The tension belts can only be secured on fixed frame parts. Foot rests, side guards, back or seat adapters are not suitable for this.
- Secure all removed parts of the wheelchair in the vehicle so that they cannot hurt anyone in case of sudden braking.

ATTENTION

There is a risk of getting hurt from loose, flying objects such as leg supports, seat shells, wheels, sticks, bags etc.

Inform yourself by your car salesman about safely securing the wheelchair with lashing exes or other suitable safety measures in your vehicle before transporting the wheelchair.

2.10.1 Transport in public transportation

In every public transportation a spot must be provided to place the wheelchair according to the EG-guideline 2001/85/EG.

ATTENTION

The spot in public transportation is only arranged for EMPTY wheelchairs.

ATTENTION

Place the wheelchair in the provided area opposite the driving direction so that the backrest and a side guard rest securely on the edge of the provided area.

- The wheelchair is not allowed to shift in case of an accident.
- Close the wheel lock.
- During the drive leave the wheelchair and seat yourself in the provided seat next to the spot for your wheelchair.
- If available, use the seat belt!

Let someone help you get in and out of the public transportation,

- so that you don't get stuck in the crack between the door and the sidewalk,
- so that you don't panic
- so that your claim for the marked seat possibly gets more emphasis,
- so that you can be helped getting into the seat and tying down the wheelchair.

2.10.2 Transport in other vehicles

Wheelchairs can never reach the stable features of a firmly mounted car seat because of their purpose and light build.

ATTENTION

Thus, we recommend you to NOT use the wheelchair as a seat while transporting in a vehicle.

READ

Read our info brochure "Crash Test ISO 7176-19". Here, the potential dangers and regulations of the ISO 7176-19 are described.

ATTENTION

Only wheelchairs that have successfully passed a dynamic crash test according to ISO 7176-19 are allowed to be used as a seat in a vehicle.

Our successfully tested wheelchairs are provided with this international symbol on the type sign and are additionally marked on our order form with our "crash test button".

If necessary, inform yourself by your retailer or under www.sorgrollstuhltechnik.de, if your model is approved as a seat in a vehicle.



2.11 OTHER RISKS

⚠ ATTENTION

After a collision, contact your rehab service station to check the carriage, frame and Bowden cables and have the damages fixed.

▶▶ INDICATATON

Avoid direct sunrays. Dark parts on the wheelchair can heat quickly and can possibly cause burns.

⚠ ATTENTION

FIRE RISK from the textile parts (seat shell and back covering, seat cushion or plastic parts). Keep sources of ignition away from the wheelchair.

⚠ ATTENTION

Hand rims heat up from strong friction especially from braking while driving fast or from driving downhill for a while.

▶▶ INDICATION

For sensitive skin we recommend to wear gloves as used for cycling (finger stalls with a leather inner surface—but NEVER wool gloves).

⚠ ATTENTION

RISK OF HAND INJURY from turning parts. Do not grab in between the spokes of the driving wheel or between the rear wheel and the knee lever brake.

⚠ ATTENTION

Do not use the wheelchair in damp rooms or drive in salt water with it. Important parts may corrode and not work properly anymore, whereby the driving qualities or the lifespan of the wheelchair are negatively influenced.

⚠ ATTENTION

The position of the driving wheels in the axle plate can only be changed by a qualified specialty store! It influences the focus (tilt ability) and the functionality of the knee lever brake.

⚠ ATTENTION

Do not put your fingers between the hand rims and the driving wheels. (Grooved wheels with built in hand rims make this impossible.)

⚠ ATTENTION

Be cautious by tight spots: You can bruise your fingers (4) and/or damage the hand rims.

⚠ ATTENTION

From braking with the hand rims, heat occurs through friction. If necessary, use leather gloves as used for cycling.

⚠ ATTENTION

Regularly check the screwing and the secure position of the hand rims according to the maintenance plan.

⚠ ATTENTION

Regularly check the secure position of the spokes according to the maintenance plan.

⚠ ATTENTION

From strong sunrays, the wheels can heat up to 42° and you could burn yourself.



3 Handling

3.1 WHEELS

3.1.1 Quick release axle wheels

All of our rear and 12" wheels are equipped with quick release axles for fast removal.

(1) To release or apply the quick release axle, push the lock button (A) in the middle of the wheel nub and release it after the action.

(2) After applying, the lock ball (A) must be completely in sight at the end of the quick release axle. The wheels should not be able to be removed.

Be sure to regard the following points:

- Wheels are turning parts and can cause injuries to fingers.
- After fastening the wheels, check the secure hold of the quick release axle.
- (2) Check the small lock ball (tension spring) (A) at the end of the quick release axle to be sure it functions properly.
- Check the air pressure of the rear wheels regularly, in order to ensure the functionality of the brakes!

With camber of wheels the toe in can be corrected if needed (see service record under "track alignment").

⚠ ATTENTION

It is absolutely necessary that you let your rehab technician do the required work.

3.1.2 Drum brake wheels

To apply or remove please proceed as described with the rear wheels.

⚠ ATTENTION

The drum brake wheels' brake pads are extremely sensitive and can lose their functionality from dirt or scratches on the brake pads. Remove lint and dirt from the brake pads regularly with a soft brush. Check the functionality of the Bowden cables regularly, in short intervals.

(3) To slow the ride down, the carer pushes both brake levers simultaneously (A).

(4) To secure the wheelchair, pull both levers (A) up and latch the small lock levers (B) in the grooves (C). The drum brakes are now blocked.

To unlock the blockage, pull both brake levers (A) a little bit higher to unlock the small lock levers (B).

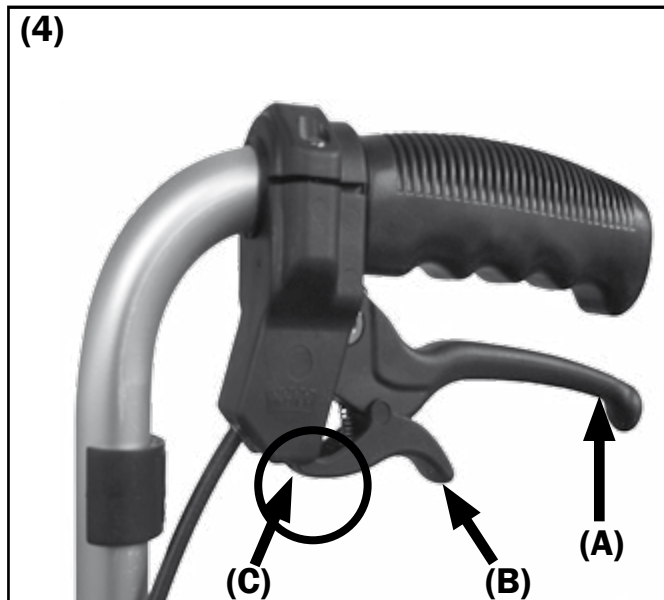
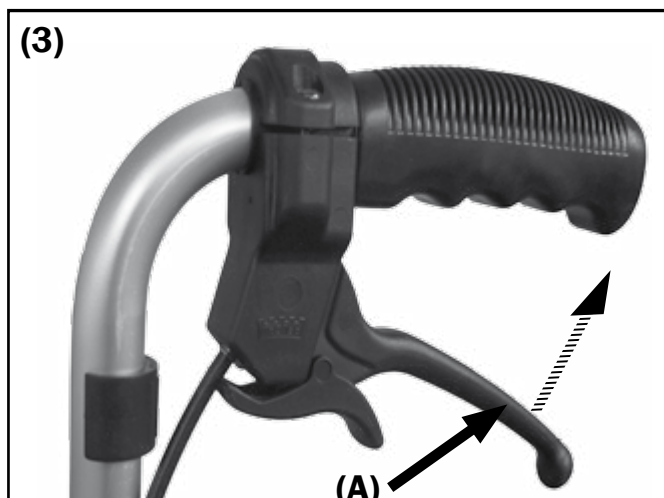

3.1.3 Double hand rim

Moving a wheelchair with a dual hand rim requires a lot of practice. Familiarize yourself, with the help of an experienced carer and in familiar surroundings, with the technology of this type of particular way of driving.

(1) When transporting etc. remove the telescopic tube **(A)** by pushing both ends together. Unlock **(B)** the rear wheels and remove them.

(2) To set them back on proceed in the same way and pull the telescopic tube over the wheel axle **(C)**. Make sure the seat is correctly secured in place. Before reusing the wheelchair the lock **(B)** must be activated.

⚠ ATTENTION

To brake you must apply the same pressure to the hand rims (inside and outside), otherwise you will swerve unwillingly and become a hazard to yourself and your surroundings.

⚠ ATTENTION

Especially when driving downhill, make sure that you are able to bring your wheelchair to a stop at any time or have someone help you.

3.2 CASTERS

⚠ ATTENTION

After a collision a qualified retailer must immediately check the wheelchair for possible damages and if necessary make repairs.

At the first sign of the caster shaking (especially during fast drives or on slopes) slow down.

Precede the same with caster with a change set as with the quick release axles of the rear wheels.

⚠ ATTENTION

Caster axles, caster forks and quick release axles should be freed from lint and dirt regularly.

Locking

(3) In order to unlock the casters, pull the locking bolt **(A)** forward and turn it 90° so that it clasps in the lock groove **(B)**.

In order to lock the casters, pull the locking bolt **(A)** a little more forward, turn it 90° and let it slide into the guide slot **(C)**.

At the next turn of the caster the bolts will automatically clasp into a forward position and lock them from driving straight ahead.

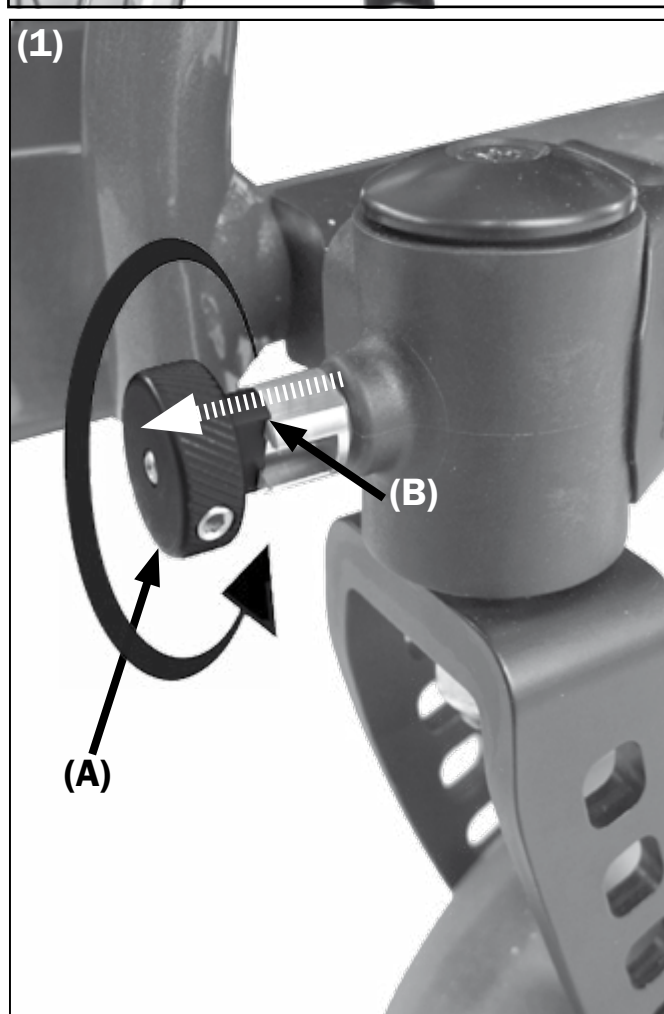
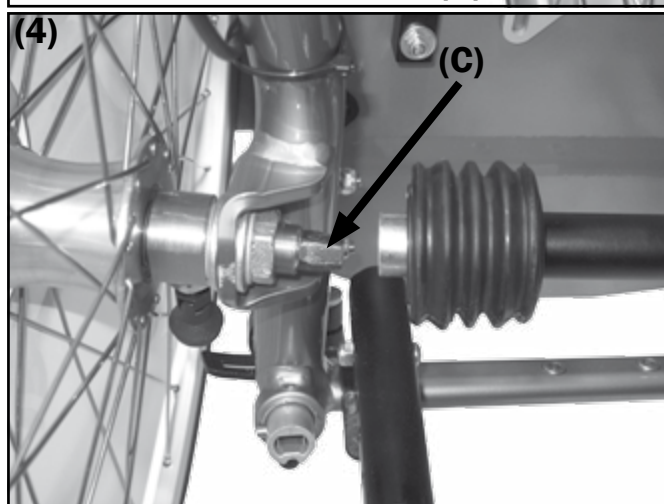
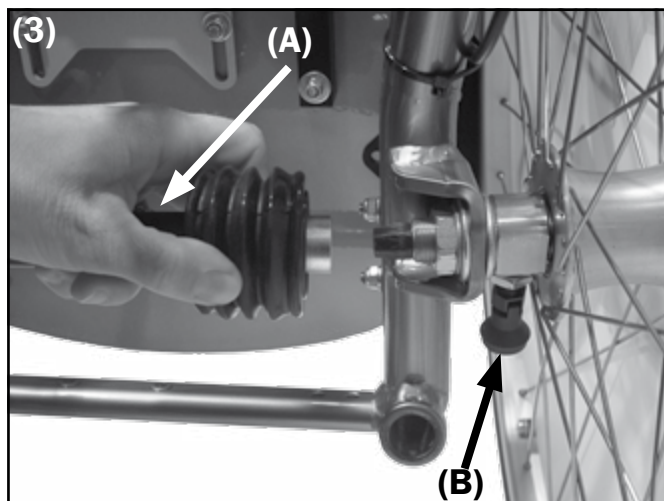

3.3 SPECIAL HAND RIMS

3.3.1 Knob hand rims

⚠ ATTENTION INJURY RISK!

Regard that the knob hand rims turn when you are being pushed!

⚠ ATTENTION

Braking with pressure on the hand rims is not possible. This applies especially when driving downhill. Let an experienced and strong carer assist you.

3.3.2 Hand rim covers / Maxgrepp hand rims

⚠ ATTENTION

All hand rim covers and the Maxgrepp hand rim are made out of several black synthetic materials and can heat to over 42° in the sun.

⚠ ATTENTION

Under unfavorable circumstances the black coating can stretch from the heat and can detach from the hand rim.

3.4 SEAT

The seat is tightly screwed on to the frame. The settings for the individual grip point are done by your rehab technician.

3.5 BACK

3.5.1 Standard back

For safety reasons please let your rehab technician do all the settings.

3.5.2 Back extension submersible

(1-3) To extend and submerge the back extension proceed as follows:

- remove the head cushion (A),
- loosen the star knob screws (B) on both sides,
- pull the back extension equally up,
- (Attention: do not tilt!)
- turn both star knob screws (B) tightly and
- fasten the head cushion (A) on the front of the back extension with the available Velcro bands.

⚠ ATTENTION

THE SUBMERSIBLE BACK EXTENSION IS NOT SUITABLE AS A HEAD REST FOR TRANSPORTING IN A VEHICLE!

3.6 SIDE GUARD/SKIRT GUARD

The side guard and the skirt guard are screwed on to the wheelchair by us according to the wheel size.

⚠ ATTENTION

Between side guard/wheel cover and rear wheels is an INJURY RISK. Do not grab between the side guard and the rear wheels.

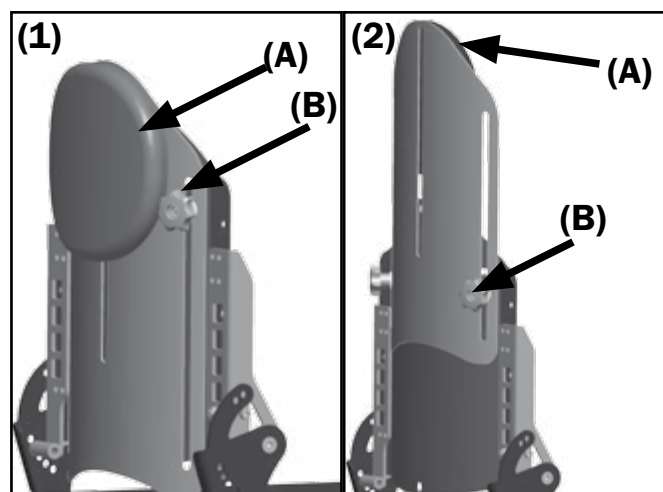

3.7 PUSH AIDS

⚠ ATTENTION

All push aids (push handles/push bails) are only there TO PUSH the person in the wheelchair. NOT TO CARRY.

For all various push aids please regard:

⚠ ATTENTION

THE TRIPOD SPRING (2B+3B) MUST ALWAYS BE VISIBLY STICKING OUT AT THE END OF THE TUBE AT THE BOTTOM OF THE HOLDER (1-3C) (See picture 3).

⚠ ATTENTION

PICTURE 2 ONLY SHOWS THE GUIDING OF THE PUSH HANDLE/S. IN THIS POSITION THE PUSH HANDLE/S IS/ARE NOT USABLE.

⚠ ATTENTION

NEVER carry the wheelchair with passenger over an obstacle (stairs, steps, curb sides etc.).

⚠ ATTENTION

The eccentric clamps of the pull-out push handles can loosen under adverse conditions. Before overcoming each obstacle, be sure to check them to make sure they are tightly closed.

⚠ ATTENTION

Do not hang any objects (bags etc.) on the push aids! DANGER OF TIPPING OVER

3.7.1 Push bails /Push handles

Proceed in the same manner with all kinds of push aids.

Height adjustment:

- open the eccentric clamp/s (A),
- place the push handle/s or bar (B) in the desired position,
- close the eccentric clamp (A) tightly.

Attaching (2+3 previous page):

- open eccentric clamp (A),
- push the tripod spring (B) inward,
- guide the push handle in the bracket (C)
- until the stand spring becomes visible at the bottom of the bracket.
- Close the eccentric clamp (A).

Detaching (2+3 previous page):

- open the eccentric clamp (A),
- push the stand spring (B) inward so that it can glide through the bracket (C),
- pull the push handle out of the bracket (C).

Children cannot estimate the swinging area of the push handle/s or push bail/s while playing and can hurt other children. It is recommended to detach the push handle/s or push bail/s for this reason.

⚠ ATTENTION

Regard the safety instructions.

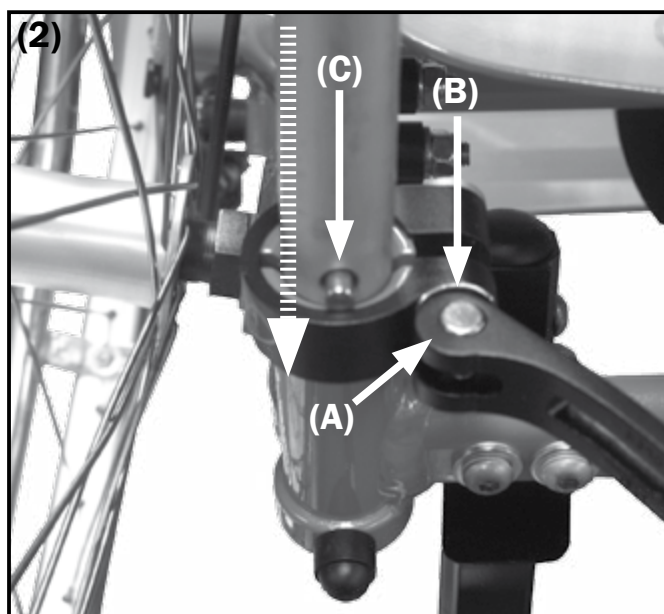
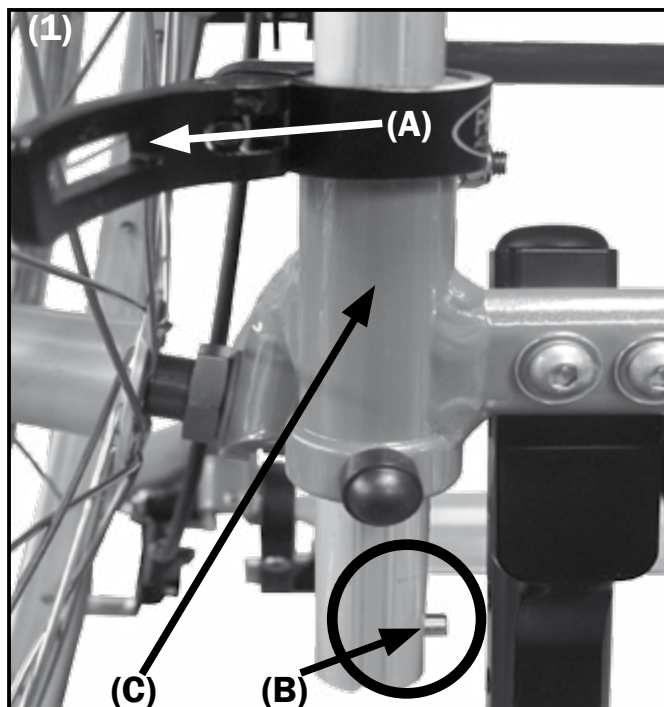

3.7.2 Angle adjustment push aids

Adjusting the angle on the **push bail**:

- **(1)** push the locking knobs **(A)** on both sides at the same time,
- adjust the bail, while pushing the locking knobs **(A)**, in the desired position
- and then let go of the locking knobs **(A)**. They stick out about 1 cm over the adjustment element.

Adjusting the angle on the one-hand push aid:

- **(2)** Loosen the eccentric clamp **(A)**,
- adjust the push handle to the desired position,
- retighten the eccentric clamp **(A)**.

⚠ ATTENTION

Regard the safety instructions.

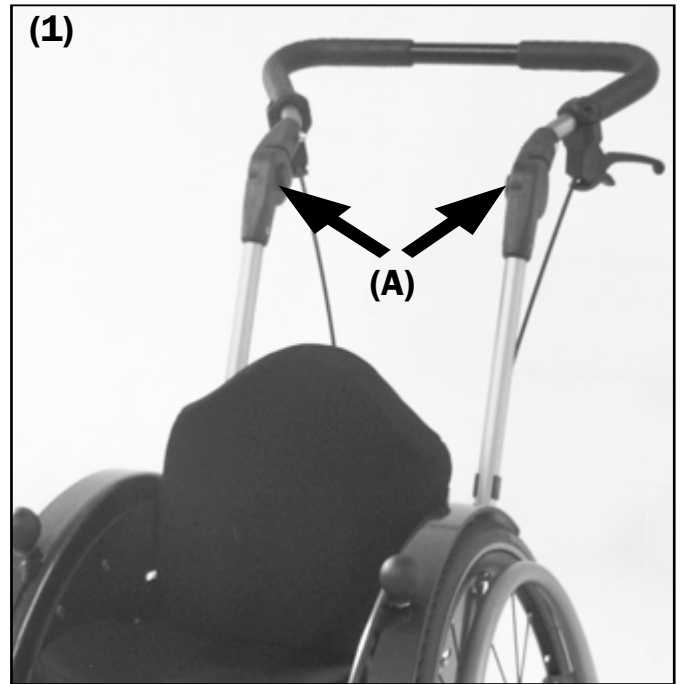

3.7.3 Tensioning force of eccentric clamp

(3) The eccentric clamp **(A)** is fixated on the opposite side of the bracket **(B)** with an adjusting screw **(E)**. From turning the eccentric clamp **(A)** its tensioning force changes.

Adjusting the tension force

- **(3)** open the eccentric clamp **(A)**,
- correct the clamp force with the adjusting screw **(E)**,
- close the eccentric clamp **(A)** and check its functionality.

⚠ ATTENTION

Check the functionality of the eccentric clamp in the stand spring in short intervals.

⚠ ATTENTION

The pushing aids should not be able to be moved in the bracket **(D)** when the eccentric clamp/s is/are in a closed position.

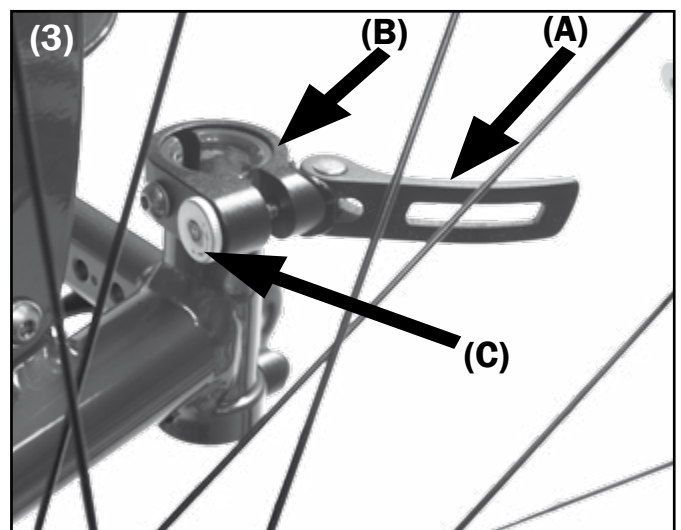
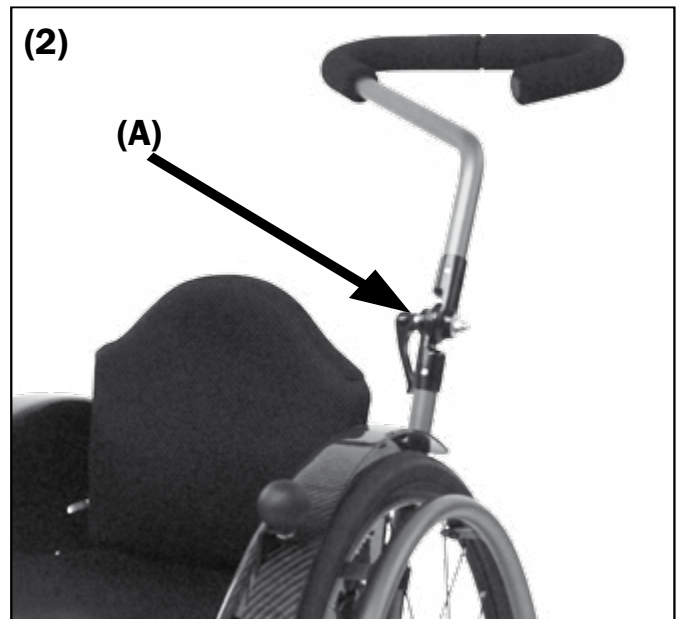

3.8 LEG SUPPORTS

▶▶ INDICATION

The leg support is ideally set when the whole thigh, to about 4 fingers (hand without thumb) width in front of the hollow of the knee, lies equally on the seat while the leg is standing at a right angle on the footrest.

A too high set footrest can cause a bent pose in the pelvic area, a too low set footrest can cause jams in the thigh and trigger spasms.

⚠ ATTENTION

NEVER LIFT/CARRY THE WHEELCHAIR BY THE FOOTREST WHEN SOMEONE IS IN IT:

▶▶ INDICATION

For safety reasons, let your rehab technician do all setting and adjustment work.

3.8.1 Standard leg support

(1) The standard leg support is set by your rehab technician according to your correct measurements. Should change be necessary please contact him.

3.8.2 Leg support foldable

(2) In order to get in, fold the footplate back. As soon as the child is sitting safely in the wheelchair lift their legs, fold the foot plate back to the front and position the child's feet.

3.8.3 Locking

(3+4) To unlock:

- Pull the latch (A) out of the slot (B)
- and turn it 90°,

(3+4) To lock:

- Place the foot plate in the locking position,
- turn the latch (A) again 90°,
- until it has snapped into the slot (B).

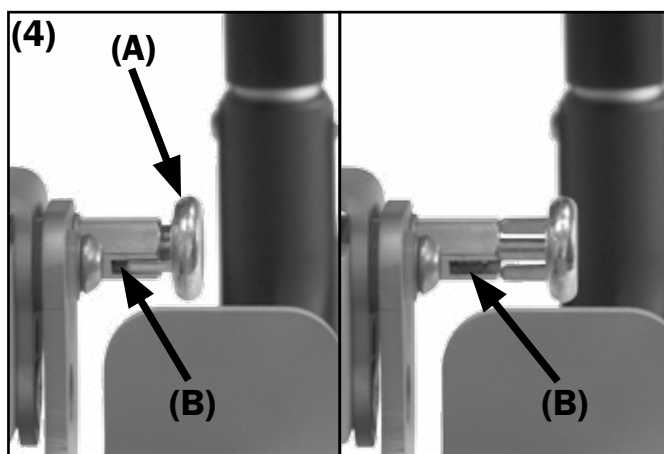
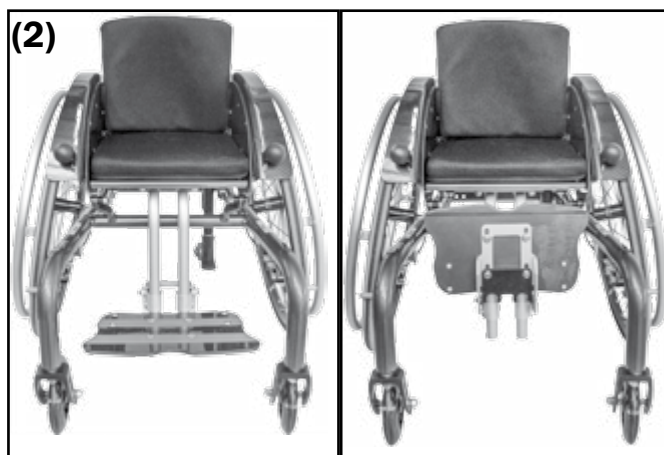

3.9 BRAKES

⚠ ATTENTION

THE KNEE LEVER BRAKES ARE ONLY TO BE USED FOR PLACING THE WHEELS IN A RESTING POSITION. THEY ARE NOT TO BE USED TO BRAKE WHILE DRIVING.

⚠ ATTENTION

While braking, forces occur that you must be able to handle. Therefore here are important indications. A wheelchair is generally (when physically possible) slowed down when simultaneous pressure is applied with both hands on the hand rims. Different pressure causes different brake force and automatically causes (unwanted) swerving. While driving downhill a higher strain for braking occurs. Do not shy away from getting help. Before each ride with your wheelchair, be sure to check the functionality of the brakes.

⚠ ATTENTION

Possible damages or malfunctions can occur from:

- dirty or falsely adjusted drum brake,
- defected Bowden cable,
- a great distance between brake bolts and tire,
- too low tire pressure,
- wetness, snow, mud etc.,
- worn off profile,
- worn off brake bolts,
- loose brake bolt screws.

3.9.1 Drum brake as driving brake

(1) In order to brake, pull the control lever up (A) and apply the same pressure to both brake levers otherwise you will swerve unwillingly. Only use the blocking lever (B) to secure the control levers in a locked position.

3.9.2 Drum brake as wheel lock

(2) To fasten the drum brake:

- pull the lever up (A) and lock the blocking levers (B) in the notches (C).

To unlock:

- pull both levers (A) a little further up until the blocking levers (B) automatically unlock.

3.9.3 Knee lever brake (wheel lock)

(3+4) To lock the wheel lock:

- push both control levers (A) forward until they snap into the new position and the brake pressing bolts (A) lie tightly on the tire cover.

⚠ ATTENTION

Consider the safety information and the possible impairments.

⚠ ATTENTION

The wheelchair is not usable until all function defects have been fixed.

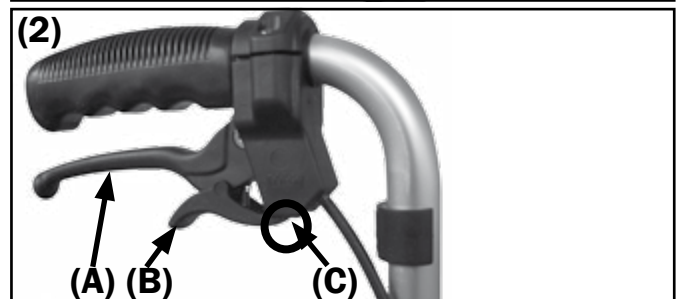
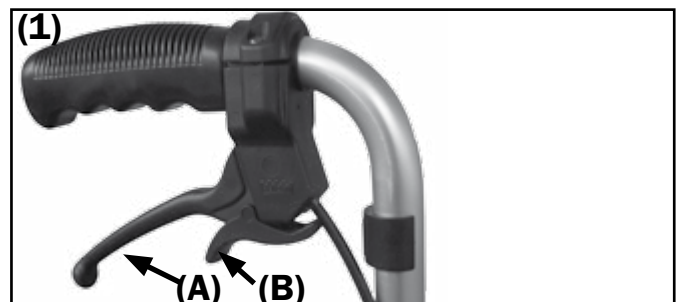

3.10 ANTI-TIPPER

(1) To activate

- push the anti-tipper (A) down using the tread element (B),
- turn it 180°
- and let go so the positioning slot snaps into the arresting bolt (C) inside the tube.

To deactivate

- push the anti-tipper on the tube (A) slightly further down,
- turn it 180° and let go so it snaps into the positioning slot.

ATTENTION

Please read the respective chapters of the SAFETY INSTRUCTIONS.

ATTENTION

Make sure that the extension is always firmly snapped into its final position because a loose anti-tipper cannot fulfill its function properly and may cause injuries of the assistant's ankle area.

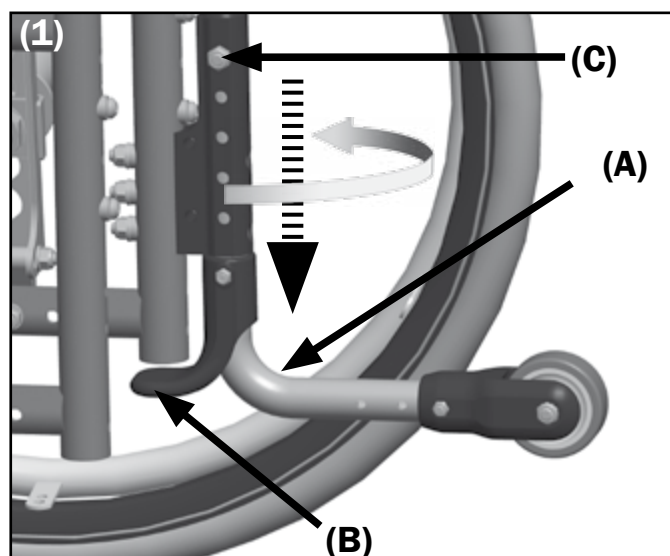

3.11 HEAD RESTS

There are two versions of the head rest - with a square-type tube (2) or a special section tube (3). Both kinds can be adjusted to the user in the same way:

(2+3) Height adjustment:

- open the eccentric clamps (A)/star screw (A),
- adjust the desired height,
- tighten screws/clamps (A) firmly.

Adjustment of distance:

- open clamp lever (B),
- adjust the desired distance,
- tighten clamp lever firmly.

ATTENTION

The head rest is only suitable for transportation in a passenger car to a certain degree. The reservations and requirements described in our "crash test" brochure concerning the use of the head rest in a passenger car are absolutely binding!

ATTENTION

We recommend using a head support firmly installed in the vehicle (not part of the wheelchair) for transportation in a passenger car.

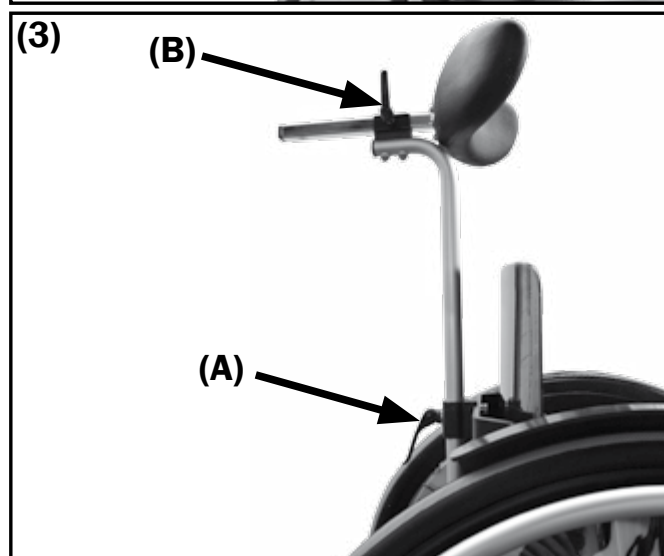
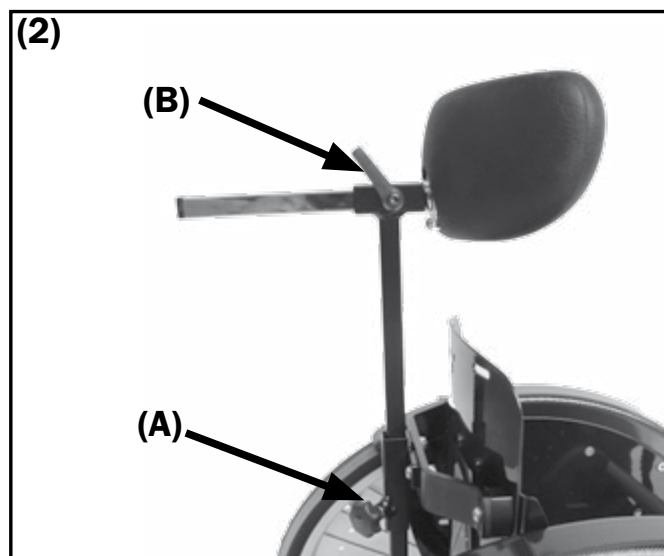

3.12 ABDUCTION WEDGE

The abduction wedge is mounted under the SeatFix. The height can be adjusted in 1,5cm intervals, the distance is infinitely variable.

Adjusting the height:

- Remove star knob screws **(A)** completely,
- shift the wedge with holder along the row of holes **(B)** into the desired height,
- replace star knob screws **(A)**.

Adjusting the distance:

- loosen star knob screws slightly **(A)**,
- slide the wedge via the star knob back and forth into the desired position,
- tighten star knob screws **(A)**.

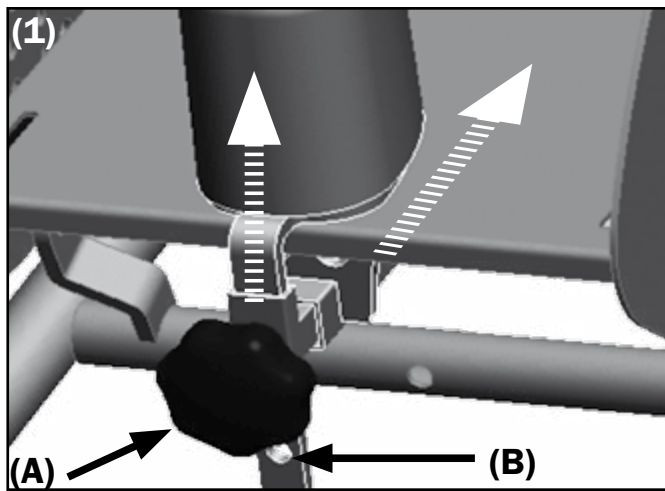

3.13 THERAPY TABLE

(1) Height setting

- loosen the setscrew **(A)**,
- place the therapy table in the desired position
- and retighten the setscrew **(A)**.

Angle setting

- loosen the clamp lever **(C)**,
- place the therapy table in the desired position
- and retighten the clamp lever **(C)**.

Depth setting/removal

- loosen the clamp lever **(B)**,
- place the therapy table in the desired position or remove it out of the holder
- and retighten the clamp lever **(B)**.
- To put it back in, proceed accordingly.

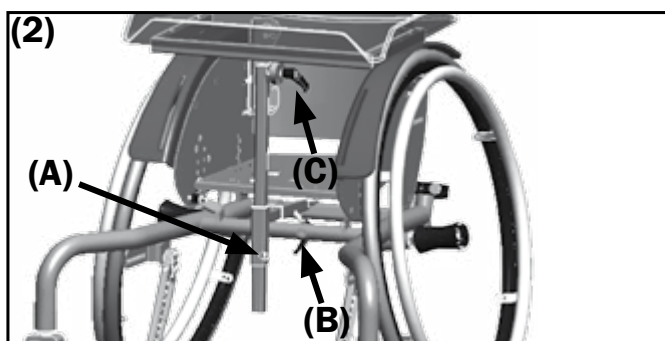

3.14 THORAX TRUSS PADS

(3) Both kinds of thorax truss pads can open and close. To do so, push the red button **(A)** and simultaneously push the truss pad frame back or forward. They snap into position when you release the button **(A)**.

(4) In order to fixate the individual frame members **(B)** or extension pieces in a certain position, tighten the screw **(C)** on the joints with a suitable Allen wrench.

(4) The position of the cushions can be adjusted or fixated through the screws **(D)**.

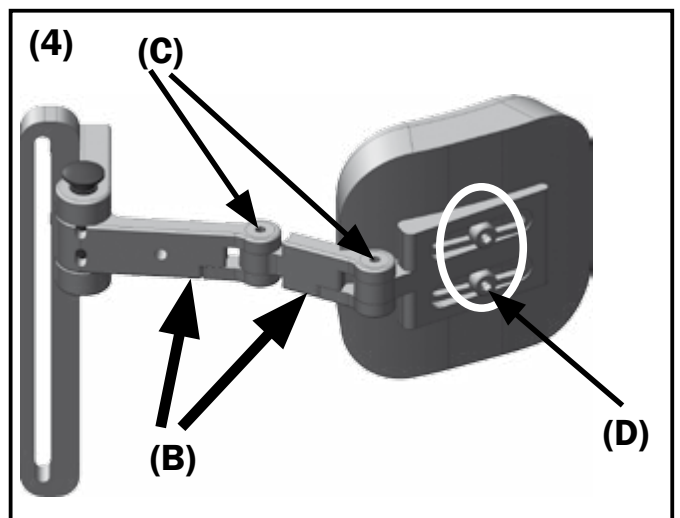
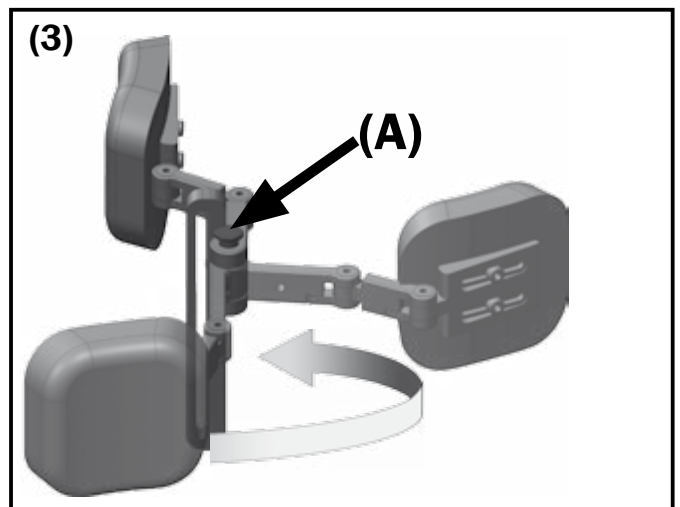

3.15 PUSH AID FOR OUTSIDE (OUTDOOR FRONT END)

(1) With the Outdoor Front End it is made possible to drive on uneven surfaces. Additionally, spasm causing vibrations when driving are visually reduced.

Mounting the Outdoor Front End

- Close the wheelchair's wheel locks.
- Tip the wheelchair slightly back and /or place on the jack up aid.
- (2) Place the end of the cone pipe (A) from the front into the holding plate (B).
- Then, guide the height adjustment (C) all the way onto the holding plate (D),
- (3) Both bushings (A) of the height adjustment (B) must be guided into the location holes (C) of the holding plate (D).
- (4) Turn the star knob (A) on the back of the holding plate (B) as tight as possible, because with it, the outdoor front end is fixated to the wheelchair.

To remove the Outdoor Front End, please proceed in the opposite order.

ATTENTION

The push aid can only be attached when the user is not in the wheelchair.

ATTENTION

The push aid is built only for a max. speed of 8 km/h. A higher speed is not allowed.

ATTENTION

A great amount of caution is to be taken when going up or downhill.

ATTENTION

We strongly advise you to let your rehab technician adjust the height of your outdoor front end. Changing the height (angle of the wheelchair backwards) influences the tilting of the wheelchair massively.

►► INDICATION

If possible (depending on the setting) it is recommended to use the anti-tipper.

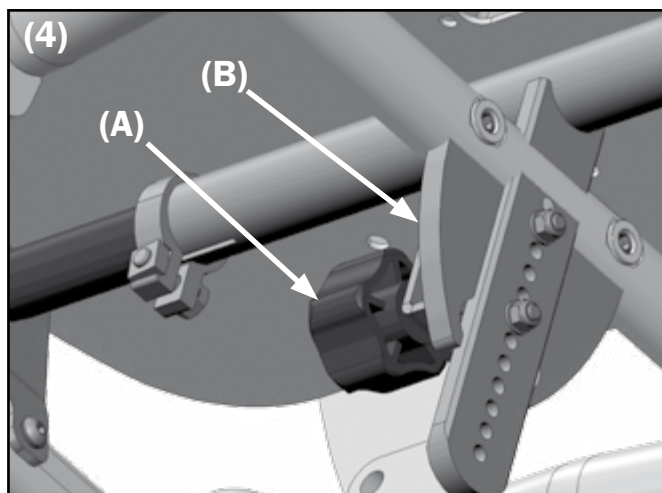
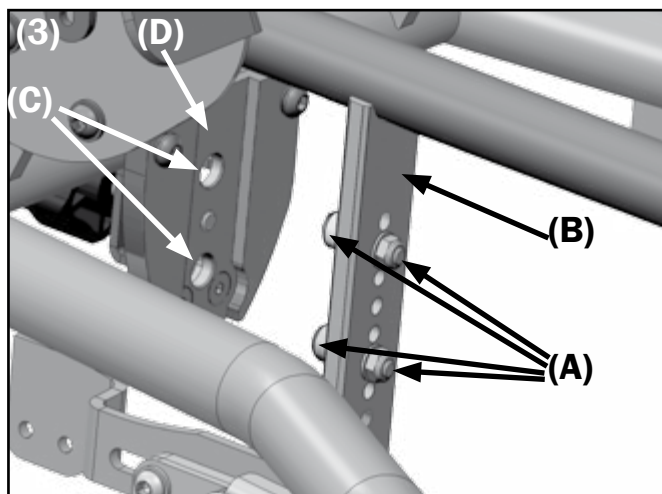
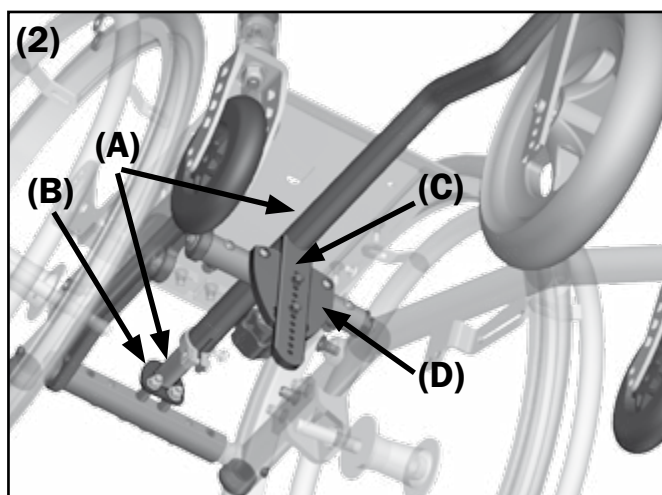

4. Repairs and Maintenance

4.1. REPAIRS

ATTENTION

Do not conduct any reparations and/or maintenance work yourself. Contact your medical supply store. There, the staff is familiar with this work, has all necessary tools and are trained rehab technicians.

If you have any questions or need help, our qualified rehab consultants are happy to assist you or turn to your specialized retailer, who is trained according to our regulations and who is capable of resuming consultations, service as well as reparations.

4.2 SPARE PARTS

ATTENTION

Safety relevant parts or assemblies can only be built on or changed by a qualified sanitary house because of the safety hazard.

ATTENTION

Only original spare parts can be used! They are available at your medical supply store.

▶▶ INDICATION

Disruption can occur from assemblies from external companies which can lead to a safety hazard. Spare parts with the respective item number and drawings are available at your specialized store and can be downloaded under www.sorgrollstuhltechnik.de or can be requested directly from us.

For a correct delivery of spare parts the appropriate series number of the wheelchair is to be stated! You will find these on the type label on the wheelchair's frame.

▶▶ INDICATION

Every change or modification done on the wheelchair by your medical store is to be enclosed in this user manual with the corresponding information such as assembling indications and/or operation instructions and the date of the alteration is to be documented in the service record.

4.3 DISPOSAL

▶▶ INDICATION

The wheelchair can only be disposed of after consultation and approval from your benefactor.

As a general rule, the disposal of the wheelchair must conform to the respective national legal regulations. You may seek information about local disposal organizations from your city or municipal administration.

Our packaging materials are 100% recyclable. Metal parts may be put to scrap metal recycling or sent to our factory. Plastic and textile parts may be recycled as well.

4.4 TIRE CHANGE

With a little bit of technical skill and suitable tools, you can fix a flat tire yourself. It is advisable to always carry a repair kit and an air pump for emergencies. Suitable air pumps can be purchased at your specialty store. An alternative would be a puncture repair spray which fills your tire with setting foam (available at the specialty store).

Dismounting

In case of a flat tire, remove the tire carefully from the rim with suitable mounting tools. Make sure not to damage the rim or the tube in the process.

Repair

Repair the tube according to the indications given on the reparation set, or replace it with a new one. Examine the rim and the interior of the tire for foreign objects which may have caused the flat tire. Only use rim bands which are in perfect condition to protect the tube from damage caused by spoke ends.

Mounting

Push the rim band over the valve and place the valve into the rim. Unscrew the valve screw nut. Now you can draw up the rim band effortlessly. Make sure that all spoke ends are covered.

Now push the lower tire part over the bead of the rim. Inflate the tire until round. Insert the weakly inflated tube into the tire cover. Check the tube for smooth fit. Then you can easily mount the upper part of the tire behind the bead of the rim with both hands. Start with the part of the valve which is faced away.

Inflation

Check if the tube is perfectly clamped between tire and cover.
Check the valve fitting.

First inflate the tire with just enough air so you can still push in with your thumb. Check the fit of the tire on the rim. If the tire cover is not centered on the rim, deflate the tire a bit and readjust it.

Then inflate the tire to its maximum operating pressure (see tire cover) and close the valve with the protection cap.

4.5 MAINTENANCE

4.5.1 Cleaning and Care

►► INDICATION

Never treat the wheelchair with a high pressure cleaner! Please use silicon free, water based cleaning and care supplies.

The indications on application given by the manufacturer are to be followed. Do not use any aggressive cleaning supplies such as dissolvers or hard brushes etc.

COATING

To tend the finish, we recommend using customary branded finish care products. Should the coating still be damaged through scrapes, hits etc. you may correct those spots with a touch up applicator available in the specialty store (apart from metallic and dormant colors).

PLASTIC PARTS

The clothing protection and similar parts consist of high quality plastic. Only clean these parts with warm water and neutral cleaning agents or soft soap.

PLEASE NOTE:

When using customary plastic cleaners, the indications on application given by the manufacturer are to be followed.

CUSHIONS AND COVERS

The covers of the molded firm seat and back parts may be removed with the zippers. We recommend washing them regularly with a mild detergent and low temperature in the washing machine.

PLEASE NOTE:

Please clean other cushions and covers (e.g. from seat shells) with warm water and hand soap. Many stains can be removed with a sponge or a soft brush.

In case of doubt, please consult the medical supply store, which built your seat shell, for advice on cleaning the cover.

FRAME

The frame and wheels must be cleaned regularly with a damp cloth and mild cleaning agent. Please dry well after.

CASTERS

Please remove rough dirt regularly from the casters, clean them with a damp cloth and mild cleaning agent and dry well. Please grease the wheel bearings and similar parts with customary grease.

PLEASE NOTE:

Please check the frame for corrosion damages as well as other damages on a regular basis. Oiling all versatile parts lightly and regularly obviates such damages and assures long use of your wheelchair.

4.5.2 Disinfection

To disinfect, water based agents should be used such as: Terralin, Quartamon, Med or Sagrotan.

The indications on application given by the manufacturer are to be minded and followed strictly.

INFORMATION

Before you disinfect the wheelchair be sure to clean all cushions and handles in the given manner.

INFORMATION

Do not use aggressive cleaning agents or solvents or hard brushes.

4.5.3 Reinstatement

►► INDICATION

Before each reinstatement the wheelchair has to go through a complete, thorough and qualified inspection and disinfection.

►► INDICATION

The necessary measures for reinstatement are to be followed through according to a validated hygiene schedule.

4.6 SERVICE/INSPECTION

4.6.1 Check list

A yearly inspection from a qualified medical store is inevitable for the safe use of the wheelchair and for a long lifespan. Furthermore, the inspections serve as proof for the suitability for use in the case of a possible reinstatement.

For safety reasons and to prevent accidents resulting from abrasion not recognized on time, a yearly inspection is designated under normal operating conditions.

►► INDICATION

This is to be done according to the service list and to be documented in the service record.

According to applicable law §33 subparagraph 1,4 BSG V (Service, Maintenance, Replacement Reserve) the inspection is part of the commitment of the benefactor and has to be acquired by him. For detailed coordination, we recommend you arrange agreements with your benefactor in the forefront of supplying medical aids.

The staff of the professional repair shop is familiar with the technique of the aid and can recognize building abrasion and if necessary they can conduct the needed reparations.

4.6.2 Check list yearly inspection

PREPARATORY WORK

If necessary, we recommend cleaning the wheelchair or individual parts of it prior to inspection.

VISUAL INSPECTION

Check frame, mounting parts and accessories for damage, defects in paint work and corrosion.

GENERAL INSPECTION

- Check all fixing screws for firm fit and retighten them if necessary.
- Check fixation of all mounted parts and readjust if necessary.
- Check fixation of all plastic parts, handles, mounted parts spoke guard covers etc. and readjust if necessary.
- Check brake lever device and extension for deflection and readjust if necessary.
- Check all spring loaded devices (quick release axle, stand spring on push handle etc.) for proper functioning and replace if necessary.

CARRIAGE

Check fixation of caster and driving wheels.

- Check functionality of the quick release axles.
- Check tires, air pressure and valve, replace if needed.
- Check caster bearing, caster fork and caster mounting bracket for condition, proper functioning and running characteristics.
- Check the firm fitting of the anti-tipper and its functionality.

BRAKES

- Make sure the brakes function properly
- Make sure the Bowden cables function properly and replace if necessary.
- Make sure the brake lever extension functions properly.

OILING AND GREASING

Clean and grease all pivot points of control levers and versatile parts as well as all bearings.

FINAL INSPECTION

- General functional check-up of all mechanical adjusting devices.
- Additional braking, steering and driving tests uphill and downhill.

4.6.3 Service List

The following service list is based on our long-term experience and is a mandatory guideline with which you can keep your wheelchair –possibly for a long time – in a safe to use condition. However, it does not give information about the extent of service or repair needed and observed on the wheelchair.

ATTENTION

Please keep in mind, the even regular maintenance is not a guarantee for a safe use and road safety. If necessary, individual repairs and/or adjustment work is to be done immediately in order to ensure you are not in great danger.



Considering possible reuse, the filled out service plan is an informative document about the mobilization of the wheelchair for the benefactor.

ATTENTION

As a participant in public traffic, the wheelchair driver is responsible for maintaining the wheelchairs functional state and safe operating condition.

ATTENTION

Insufficient or neglected care and maintenance of the wheelchair pose a significant safety risk and automatically lead to limitations of product liability.

WHEN?	WHAT?	COMMENTS
Before each use	<p>Check wheels/quick release axles for firm fit. You must not be able to pull the wheel out of the quick release axle. The arrestor button must protrude the hub visually.</p> <p>Check air pressure according to the manufacturer indication on the tire.</p> <p>ATTENTION Regularly check the brakes for proper function!</p>	<p> ATTENTION Too low air pressure and/or dirty tires as well as adverse weather circumstances can reduce the brake efficiency drastically and put you in danger. Fix all flaws yourself immediately or with an experienced carer.</p> <p>If the brake doesn't work correctly (worn out profile or braking bolt, loose brake lever etc.), contact a medical supply store immediately for qualified maintenance work.</p> <p> ATTENTION The wheelchair (with full capacity) has to stand safely with pulled brake on a ramp with a 7° (=12%) decline</p>
Preferably before each use	<p>Check all screws for proper fit.</p> <p>Check frame and back tubes for damages.</p>	<p>Please check:</p> <ul style="list-style-type: none"> • secure fit of the quick release axle, wheel adapter • angle adjustment elements (eccentric clamp or star knob screws) for proper functioning and completeness • fixation of foot rest • fixation of molded seat and back/seat shell • fixation of wheel guard • fixation of anti-tipper • proper functioning (clamping force) of all eccentric clamps • connection Velcro-fleece (seat and back belts) for proper functioning <p> ATTENTION If the welded seams are deformed and /or have fissures, contact a medical supply store immediately for qualified maintenance.</p>
Every 4 Weeks	<p>Retighten all screw joints</p> <p>Check tire profile</p> <p>Remove lint/dirt from casters</p>	<p>From daily use and the permanent vibrations screws can loosen. Therefore, we strongly recommend retightening ALL screw joints once a month.</p>
Every 2-3 months (depending on driving performance)	<p>Clean and grease all versatile parts</p> <p>Retighten spokes</p>	<p>All moving parts such as brakes, brake levers, quick release axles etc. Clean all parts thoroughly and remove old oil residue before greasing. After, Apply some drops of oil and wipe away excess oil.</p> <p>If possible have this done by your medical supply store!!!</p>
every 6 months (depending on driving performance, earlier)	<p>Check frame for cracks, corrosion and damages</p> <p>Maintain locking brake</p>	<p>Please have this done by the medical supply store! Please remove seat and back unit as well as leg support and side guards/clothing guard for better exterior visual control.</p> <p>To be conducted by the medical supply store! Inspect brakes for symptoms of fatigues or abrasion.</p>

4.7 TECHNICAL DATA

4.7.1 Measurements and dimensions

Dimension tolerance $\pm 5^\circ$

Abbreviations:

SW = seat width
SD = seat depth
BH = back height
SH = seat height
LLL = lower leg length

Data

Model: Mio
German aid index N°: 18.99.02.1012
Type: 910
Type plate on frame tube

4.7.2 Meaning of labels

The meaning of the individual labels is explained in the texts at the respective place.

The Serial number consists of

X X X X X X X X X X

Type-Nr. Order-Nr. Year

The type plate on the frame of Jump alpha has the following meanings:

4.7.3 Measurements Mio

Misprints and technical changes reserved.

Indication	Measurements		Comment
seat width (SW)	2-cm-intervals	18 to 30 cm	
seat depth (SD)	2-cm-intervals	18 to 30 cm	
back height (BH)	2,5-cm-intervals	17,5 to 35 cm	
back angle:	$\pm 10^\circ$		
camber	9°		opt. 11°
Upper edge seat to upper edge footrest	Retro frame:	10-30 cm	Without seat cushion
	Taurus frame:	15-35 cm	
Upper edge seat to ground	20"	34,0-38,5 cm	WITHOUT cushion
	22"	36,0-40,5 cm	
	24"	38,5-43,0 cm	
ETRTO wheel size	with 20"	Ø 451 mm	
	with 22"	Ø 489 mm	
	with 24"	Ø 540 mm	
absolute width of wheelchair	min.	SW + 310 mm,	
	max.	SW + 365 mm	
absolute length of wheelchair	with 20"	630 mm	without push handles!
	with 22"	695 mm	
	with 24"	745 mm	
absolute height of wheelchair	min.	500 mm	without push handles!
	max.	875 mm	
incline	max. permitted	12,3% = 7°	
descent	max. permitted	12,3% = 7°	
stability	max. permitted	12,3% = 7°	
turning circle			about 1020 mm
vehicle load capacity(max.)	50 kg		
empty weight min. with SW 20, SD 20 cm, 20" wheels, 4" polyurethane casters	6,9 kg		Equipped with frame, rear wheels, handrims, casters, wheel lock, foot rest, side guards, skirtguard and anti tipper.
wheels:	Standard- and tread, light weight wheels	optional light weight drum brake wheels	
casters:	4", 5", 5,5"	transparent with LED, full rubber black with alloy wheels, PU gray with plastic rim	
air pressure:	information on wheels (6-8 bar)		
tires:	standard wheels, light weight wheel	optional light weight drum brake wheels	
support point:	back frame cross bar		
heaviest piece:	rear wheels 0,8-1,4 kg		

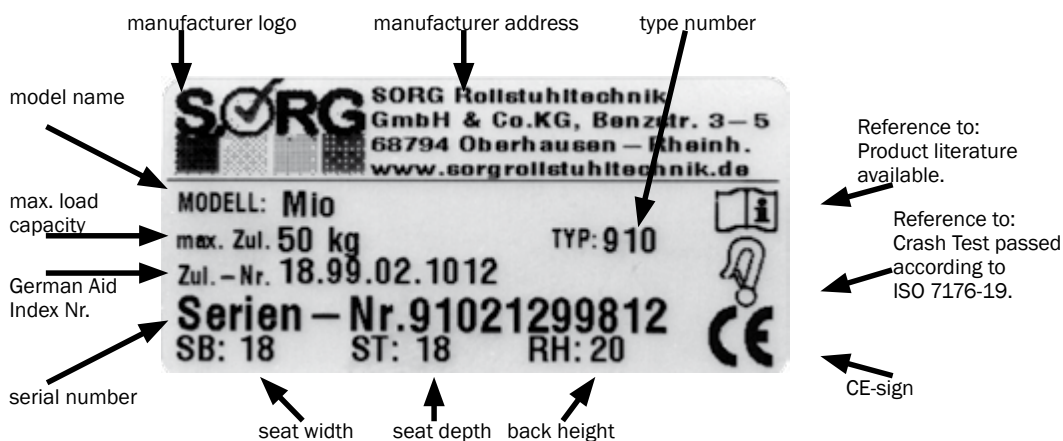

4.8 DOCUMENTATION YEARLY INSPECTION

Work done according to check list	Additional work carried out	date, signature, stamp medical supply store,
-----------------------------------	-----------------------------	--

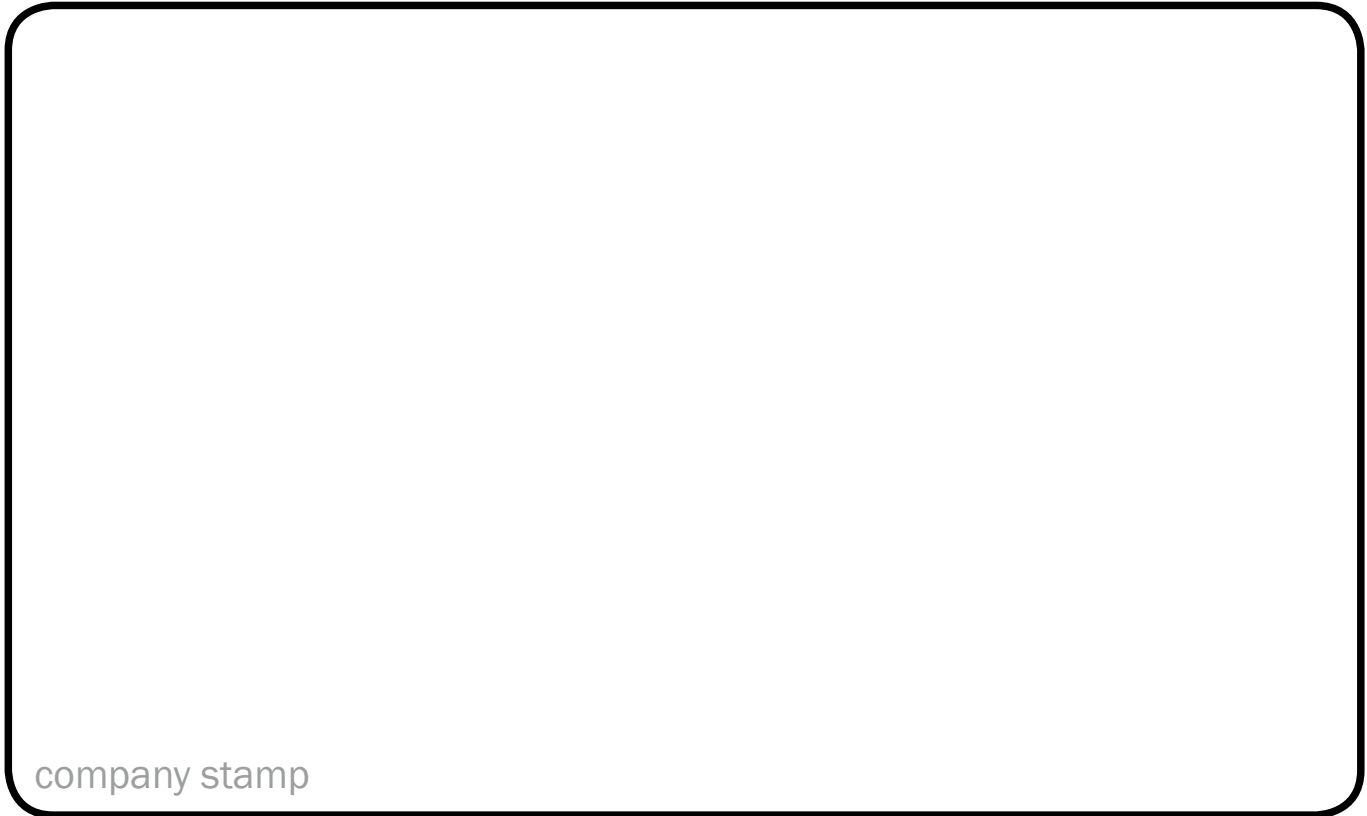

company stamp



SORG Rollstuhltechnik
GmbH + Co. KG
Benzstraße 3-5
D-68794 Oberhausen-Rheinhn.

Tel +49 7254 9279-0
Fax +49 7254 9279-10

info@sorgrollstuhltechnik.de
www.sorgrollstuhltechnik.de
Technical changes and
misprints reserved.